

CLAMPING ELEMENT | HYDRAULIC

DKHS1280-00-A

▶ PRODUCT ADVANTAGES

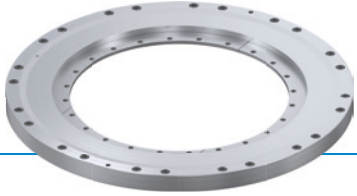

▶ Highest accuracy in rotational axis

No moving functional parts and therefore backlash-free

Drive can be taken out of the drive control

▶ Fastest closing time and pressureless safety function

Due to a low displacement volume and internal stress of the housing

▶ Market leading cycles

Housing strain stays below the elastic fatigue limit

▶ TECHNICAL DETAILS

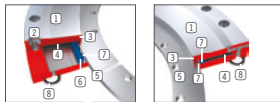
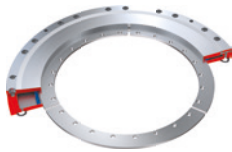

① Housing

- Holding torque due to pre-stressed, high tensile tool steel

② Housing connection

- Screw connection to the connecting construction

③ Clamping area

- Backlash-free Clamping of the rotary axis

④ Pressure chamber

- Opens the element under pressure in the elastic range

⑤ Shaft connection

- Connection with the rotary axis

⑥ Sealing

- Prestressed and self-enforcing under pressure

⑦ Retain plate

- Secures and holds the sealing in position

⑧ Hydraulic connection

- Sealing through O-Ring and surrounding cutting ring

▶ INFORMATION ON THE PRODUCTS

APPLICATION SCENARIOS

- ▶ Torque take-up of shafts
- ▶ Clamping of torque drive
- ▶ Clamping of C-axis
- ▶ Fixing and safeguarding of swivel bridge
- ▶ Clamping of spindle tilting axis

► TECHNICAL DRAWINGS

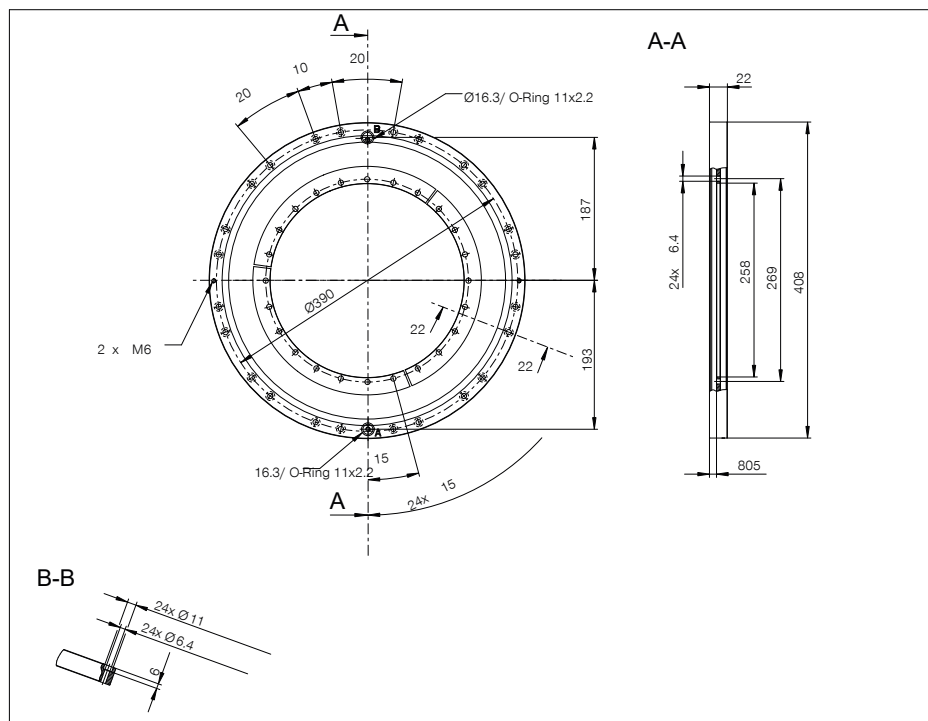

Ⓐ Hydraulic connection

Ⓒ Vent

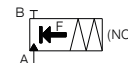

► TECHNICAL DATA

Order no.	DKHS1280-00-A
Operation	hydraulic
Theoretical holding torque ($\mu=0,1$) [N]	Fehlende Variable
Holding torque at 1 arcsec [Nm]	2400
Holding torque at 5 arcsec [Nm]	3000
Operating pressure [bar]	100.0 ... 110.0
B10d value	5,000,000
Opening time [s]	0.05
Closing time [s]	0.03
Operating temperature [°C]	5 ... +80
Weight [kg]	9
Shaft Ø [mm]	280
Function	Clamping
Condition	NC (Normally Closed) closed without pressure
Installation direction	from the front
Displacement [cm ³]	7
Certifications	CE / UKCA / LABS / REACH / RoHS

Schematic drawing. General tolerances according to DIN ISO 2768 T1-4/T2-H. Edges according to ISO 13715. The holding torque is the maximum torque that can be applied rotationally. Each rotary clamping element is tested for the specified holding torque with a lightly oiled lubricating layer (ISO-VG 68) in a 100% inspection before delivery. The use of other lubricants can influence the coefficient of friction. The operating instructions must be observed before commissioning. We reserve the right to make technical changes in the course of further development. The latest and further data can be found online and in the operating instructions at www.zimmer-group.com.