

ROTARY DISTRIBUTORS

SERIES DVR

▶ PRODUCT ADVANTAGES

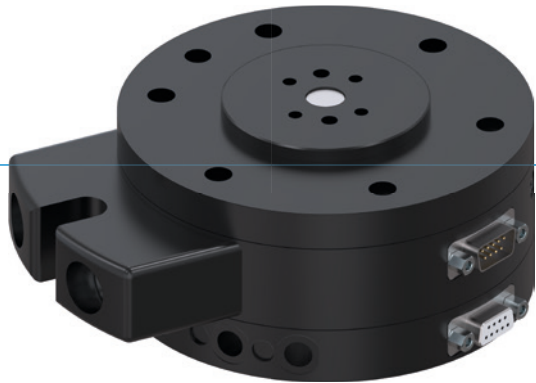

▶ **Compact media transfer system**

This D1 media exchanger makes cable breaks and undefined interference contours through the power supply line a thing of the past

▶ **Flat design**

This structure reduces the moment load for your robot to a minimum and makes it possible to use smaller and more affordable sizes

▶ **Gold contact**

Allows flexibility for transmission because you can transfer everything from the smallest flows up to 250 volts and 6 amps with process reliability

▶ THE BEST PRODUCT FOR YOUR APPLICATION



▶ **Our products welcome the challenge!**

Extreme conditions, all over the world—our tried and tested components and systems give you endless possibilities.

Find the best product for your specific use:

www.zimmer-group.com

► BENEFITS IN DETAIL

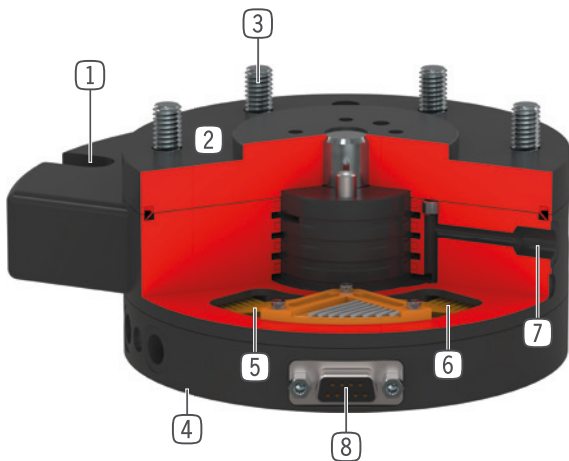

- ① **Torque brace**
 - supports the rotor during rotation (movement)
- ② **Robust, lightweight housing**
 - Hard-coated aluminum alloy
 - nitrated steel
- ③ **Robot flange**
 - partial mounting circle in accordance with EN ISO 9409-1
- ④ **Direct air connection**
 - to WWR series
- ⑤ **Spring system**
 - from size DVR63 double fitting
- ⑥ **Collector ring**
 - hard gold coated
 - transferable to finest currents
- ⑦ **Up to 8 way integrated air feed-through**
 - for hoseless air transfer
 - hose package does not have to be pivoted
- ⑧ **Up to 12 pole energy transfer**
 - for cable-free signal transfer
 - no cables are subjected to torsion

► TECHNICAL DATA

Installation size	Connecting flange according EN ISO 9409-1	Pneumatic energy transfer	Electrical energy transfer
		[Quantity]	
DVR40	TK 40	4	4-pole
DVR50	TK 50	4	4-pole
DVR63	TK 63	6	6-pole
DVR80	TK 80	6	6-pole
DVR100	TK 100	4 / 8	8-pole
DVR125	TK 125	4 / 8	12-pole
DVR160	TK 160	4 / 8	12-pole

► FURTHER INFORMATION IS AVAILABLE ONLINE



All information just a click away at: www.zimmer-group.com. Find data, illustrations, 3D models and operating instructions for your installation size using the order number for your desired product. Quick, clear and always up-to-date.

ROTARY DISTRIBUTORS

INSTALLATION SIZE DVR50

▶ PRODUCT SPECIFICATIONS



▶ Variable installation position

Shows the maximum handling weight depending on acceleration and lever arm. Does not replace the technical design.

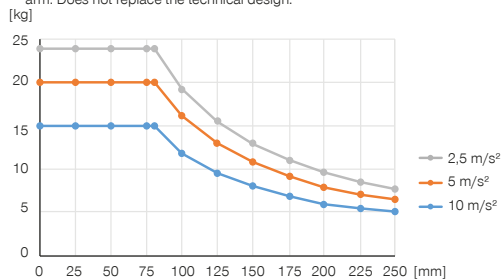

▶ Forces and moments

Shows static forces and moments which may impact on the rotary distributor.

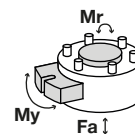

Mr [Nm]	60
My [Nm]	60
Fa [N]	800

▶ INCLUDED IN DELIVERY



4 [piece]
Cylinder Screw
C7984060129



4 [piece]
O-Ring
COR0025100

▶ RECOMMENDED ACCESSORIES



ENERGY SUPPLY



GVM5
Straight Fittings - Quick Connect Style



WVM5
Angled Fittings - Quick Connect Style



CONNECTIONS / OTHER



KAG500B4
Plug-in connector Straight Cable 5m - Socket M8 (female)



CONNECTIONS / OTHER



KAG500S4
Plug-in Connector Straight Cable 5m - Connector M8



KAW500B4
Plug-in connector Angled Cable 5m - Socket M8 (female)



KAW500S4
Plug-in Connector Angled Cable 5m - Connector M8

Order no.	Technical data
	DVR50I4
Connecting flange according EN ISO 9409-1	TK 50
Pneumatic energy transfer [Quantity]*	4
Electrical energy transfer	4-pole
Max. current [A]	3
Max. voltage [V]	24
Max. acceleration [m/s ²]	22
Maximum speed [1/min.]	120
Maximum speed [°/s]	720
Radial run out +/- [mm]	0.02
Axial run out +/- [mm]	0.02
Constant torque [Nm]	1
Loose torque [Nm]	1.5
Operating pressure max. [bar]	10
Operating temperature [°C]	5 ... +80
Moment of inertia [kgcm ²]	8.1
Protection to IEC 60529	IP40
Weight [kg]	0.62

*Vacuum possible

