

3-JAW CONCENTRIC GRIPPERS

INSTALLATION SIZE GD1708

▶ PRODUCT SPECIFICATIONS



▶ Gripping force diagram

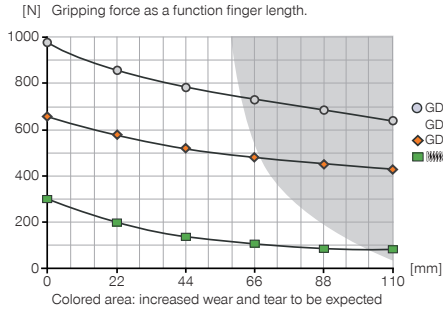

▶ Forces and moments

Displays static forces and moments that can also have an effect, besides the gripping force.

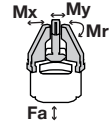

Mr	30
Mx	45
My	30
Fa	1300

▶ INCLUDED IN DELIVERY



Centering Disc

BDST40800

▶ RECOMMENDED ACCESSORIES



Straight Fittings - Quick Connect Style

GV1-8X6

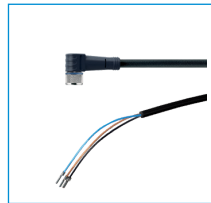

Plug-in connector Angled Cable 5m - Socket M8 (female)

KAW500

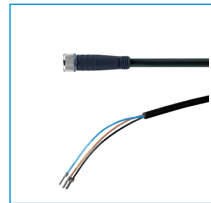

Plug-in connector Straight Cable 5m - Socket M8 (female)

KAG500



Magnetic field sensor Angled Cable 5m

MFS103KHC



Magnetic field sensor Angled Cable 0,3 m - Connector M8

MFS103SKHC



Magnetic field sensor Straight Cable 5m

MFS204KHC



Magnetic field sensor Straight Cable 0,3 m - Connector M8

MFS204SKHC

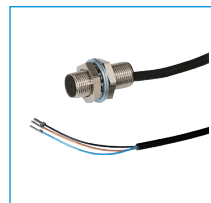

Inductive proximity switch - Cable 5m

NJ8-E2



Inductive proximity switch - Connector M8

NJ8-E2S



Universal Jaw Aluminium

UB1708

Order no.	► Technical Data*		
	GD1708N-B	GD1708NC-B	GD1708NO-B
Stroke per jaw [mm]	8	8	8
Gripping force in closing [N]**	660	960	-
Gripping force in opening [N]**	660	-	960
Gripping force secured by spring min. [N]	-	290	290
Closing time [s]	0.1	0.12	0.12
Opening time [s]	0.1	0.12	0.12
Repetition accuracy +/- [mm]	0.05	0.06	0.06
Operating pressure min. [bar]	3	5	5
Operating pressure max. [bar]	8	8	8
Operating temperature min. [°C]	5	5	5
Operating temperature max. [°C]	80	80	80
Air volume per cycle [cm³]	47	96	96
Weight [kg]	0.9	1.5	1.5

*All data measured at 6 bar

**

NC / NO

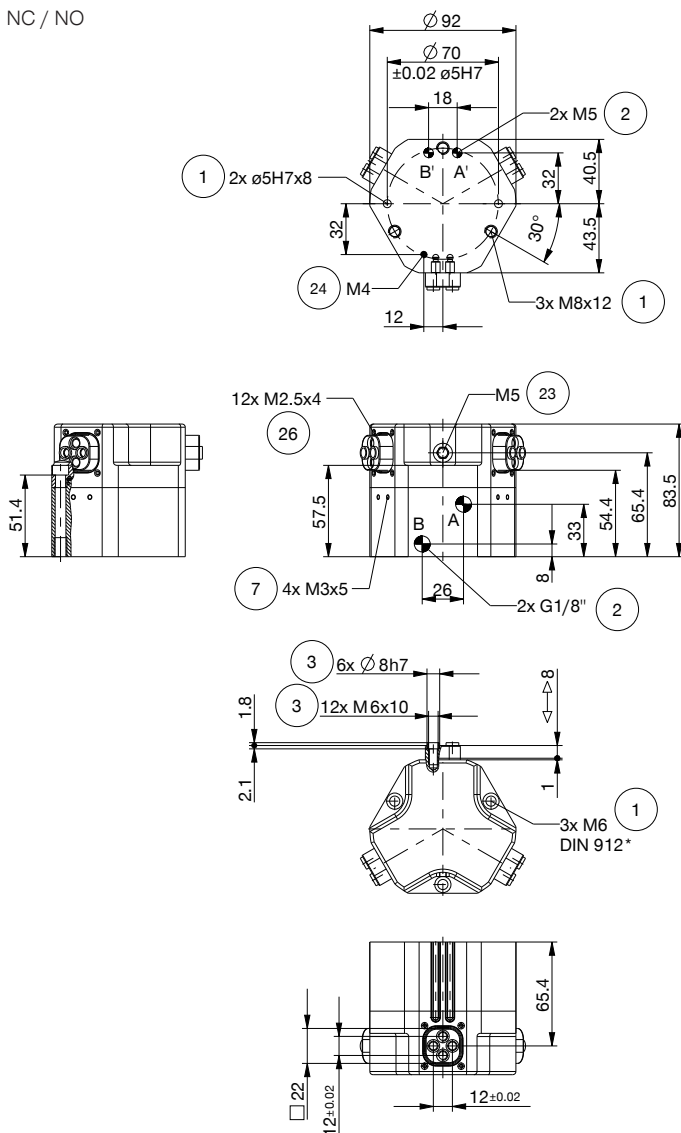

- ① Gripper attachment
- ② Energy supply
- ③ Fixing for gripper finger
- ⑦ Fixing for mounting block
- ⑬ Ventilation or purged air connection
- ⑭ Ventilation or purged air connection (alternate)
- ⑮ Fixing plate
- ⑳ Adapter
- ㉑ Gripper
- Ⓐ Air connection (close)
- Ⓑ Air connection (open)
- Ⓐ Air connection, alternative (close)
- Ⓑ Air connection, alternative (open)

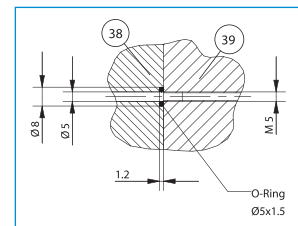

Hoseless air feed-through

