

2-JAW PARALLEL GRIPPERS

SERIES GPP5000AL

▶ PRODUCT ADVANTAGES

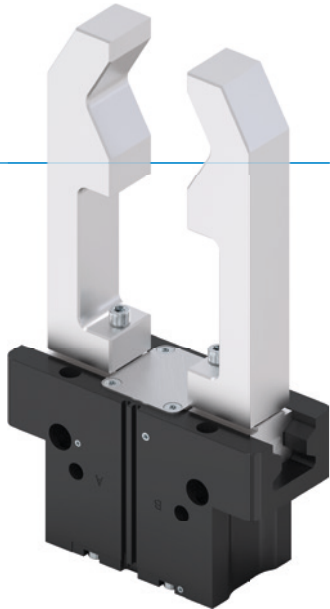

reddot design award
winner 2018



“The Alternative”

▶ Aluminum Linear Guide – The alternative

Reduced to those aspects which are the most important, the steel / aluminum guide variant offers significantly better performance when compared to a similar gripper with a T-groove travel guide, and is on par with the best principles of toothed guidance systems.

▶ Only here – larger stroke, reduced costs

If the stroke is not large enough, you do not have to change to the next size! The L variants offer the same stroke – without additional weight or increased space requirements. This saves you costs and keeps you flexible.

▶ The value promise – Consistent and without fine print

Rely on the Zimmer Group and benefit from an exclusive 24-month warranty for your GPP and GPD5000 grippers – without restrictions, even for parts that come into contact with the workpiece and wear parts. Maximum reliability, maximum productivity – 24/7!

▶ BENEFITS IN DETAIL

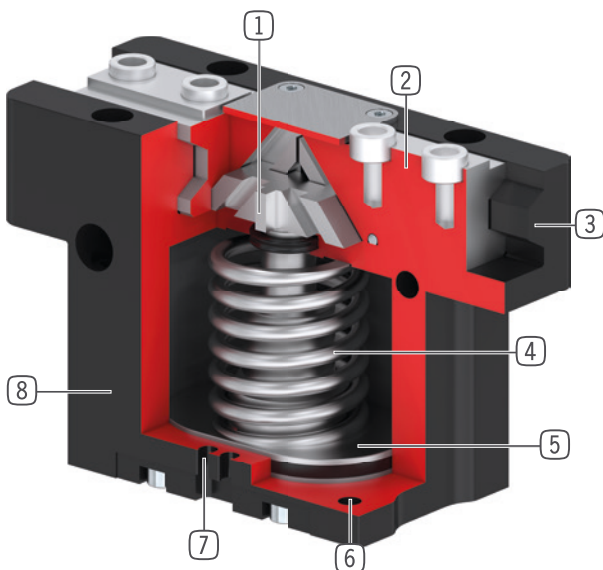

- ① **Wedge hook mechanism**
 - high forces and moments capacity
 - Synchronized gripper jaw movement
- ② **Gripper jaw**
 - Gripper fingers mounted using removable centering sleeves
 - Lubricated for life via incorporated lubrication slots
- ③ **Aluminum Linear Guide**
 - Robust prismatic guide
 - Enables attachment of long gripper fingers
- ④ **Integrated gripping force safety device**
 - Spring built into cylinder chamber as an energy store
- ⑤ **Drive**
 - Double-acting pneumatic rotor cylinder
- ⑥ **Mounting and positioning**
 - Alternatively, on several sides for customized mounting
- ⑦ **Sensing slot**
 - mounting and positioning of magnetic field sensors
- ⑧ **Robust, lightweight housing**
 - Hard-coated aluminum alloy



► SERIES CHARACTERISTICS

Installation size		Variants					
GPP50XX		N-AL-A	NC-AL-A	NO-AL-A	L-AL-A	LC-AL-A	LO-AL-A
N	Long stroke	•					
NC	Long stroke / Spring closing		•				
NO	Long stroke / Spring opening			•			
L	Enlarged stroke				•		
LC	Enlarged stroke / Spring Closing					•	
LO	Enlarged stroke / Spring Opening						•
	Aluminum Linear Guide	•	•	•	•	•	•
	15 million maintenance-free cycles (max.)	•	•	•	•	•	•
	Magnetic field sensor	•	•	•	•	•	•
	Purged air	•	•	•	•	•	•
	Cleanroom-certified	•	•	•	•	•	•
	IP40	•	•	•	•	•	•

► TECHNICAL DATA

Installation size	Stroke per jaw	Gripping force	Weight	IP class
	[mm]	[N]	[kg]	
GPP5003AL	2,5 - 4	85 - 205	0,078 - 0,093	IP40
GPP5004AL	4 - 6	130 - 295	0,15 - 0,19	IP40
GPP5006AL	6 - 8	230 - 485	0,28 - 0,34	IP40
GPP5008AL	8 - 10	390 - 750	0,51 - 0,61	IP40
GPP5010AL	10 - 13	650 - 1320	0,82 - 1	IP40
GPP5013AL	13 - 16	1115 - 1860	1,4 - 1,8	IP40
GPP5016AL	16 - 20	1650 - 2990	2,7 - 3,6	IP40
GPP5025AL	25	3280 - 4710	5,7 - 7,5	IP40

2-JAW PARALLEL GRIPPERS

INSTALLATION SIZE GPP5025AL

▶ PRODUCT SPECIFICATIONS

-AL-A

Steel / aluminum guide

▶ Gripping force diagram

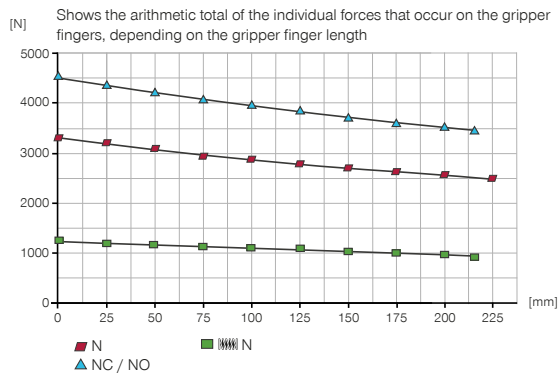

▶ Forces and moments

Displays static forces and moments that can also have an effect, besides the gripping force.

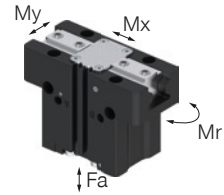

Mr [Nm]	170
Mx [Nm]	195
My [Nm]	220
Fa [N]	7000

▶ VARIANTS

-AL-A

Steel / aluminum guide

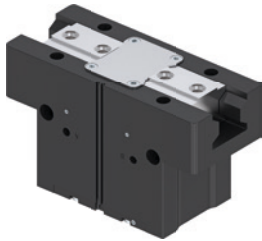

▶ TECHNICAL DATA

Order no.	▶ Technical data		
	GPP5025N-AL-A	GPP5025NC-AL-A	GPP5025NO-AL-A
Stroke per jaw [mm]	25	25	25
Gripping force in closing [N]	3280	4510	
Gripping force in opening [N]	3490		4710
Gripping force secured by spring min. [N]		1220	1220
Closing time [s]	0.33	0.28	0.57
Opening time [s]	0.33	0.57	0.28
Dead weight of mounted gripper finger max. [kg]	6.5	6.5	6.5
Length of the gripper fingers max. [mm]	225	215	215
Repetition accuracy +/- [mm]	0.02	0.02	0.02
Operating pressure [bar]	3 ... 8	4 ... 7	4 ... 7
Nominal operating pressure [bar]	6	6	6
Operating temperature [°C]	-10 ... +90	-10 ... +90	-10 ... +90
Air volume per cycle [cm ³]	420	830	830
Clean room applications according to DIN EN ISO 14644-1	4	4	4
Certifications	LABS / REACH / RoHS	LABS / REACH / RoHS	LABS / REACH / RoHS
Protection to IEC 60529	IP40	IP40	IP40
Weight [kg]	5.7	7.5	7.3

▶ Maximum gripper finger length

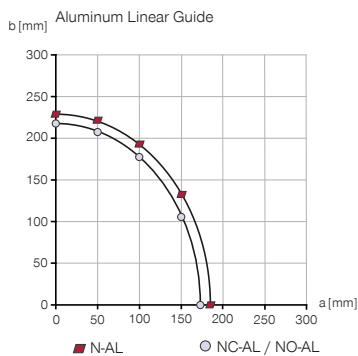

▶ Resulting gripper finger length for determining the gripping force

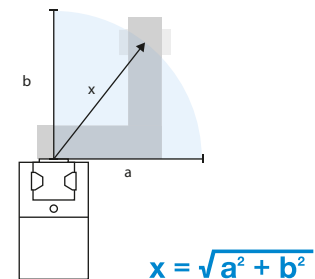

2-JAW PARALLEL GRIPPERS

INSTALLATION SIZE GPP5025AL

TECHNICAL DRAWINGS

NC / NO / LC / LO

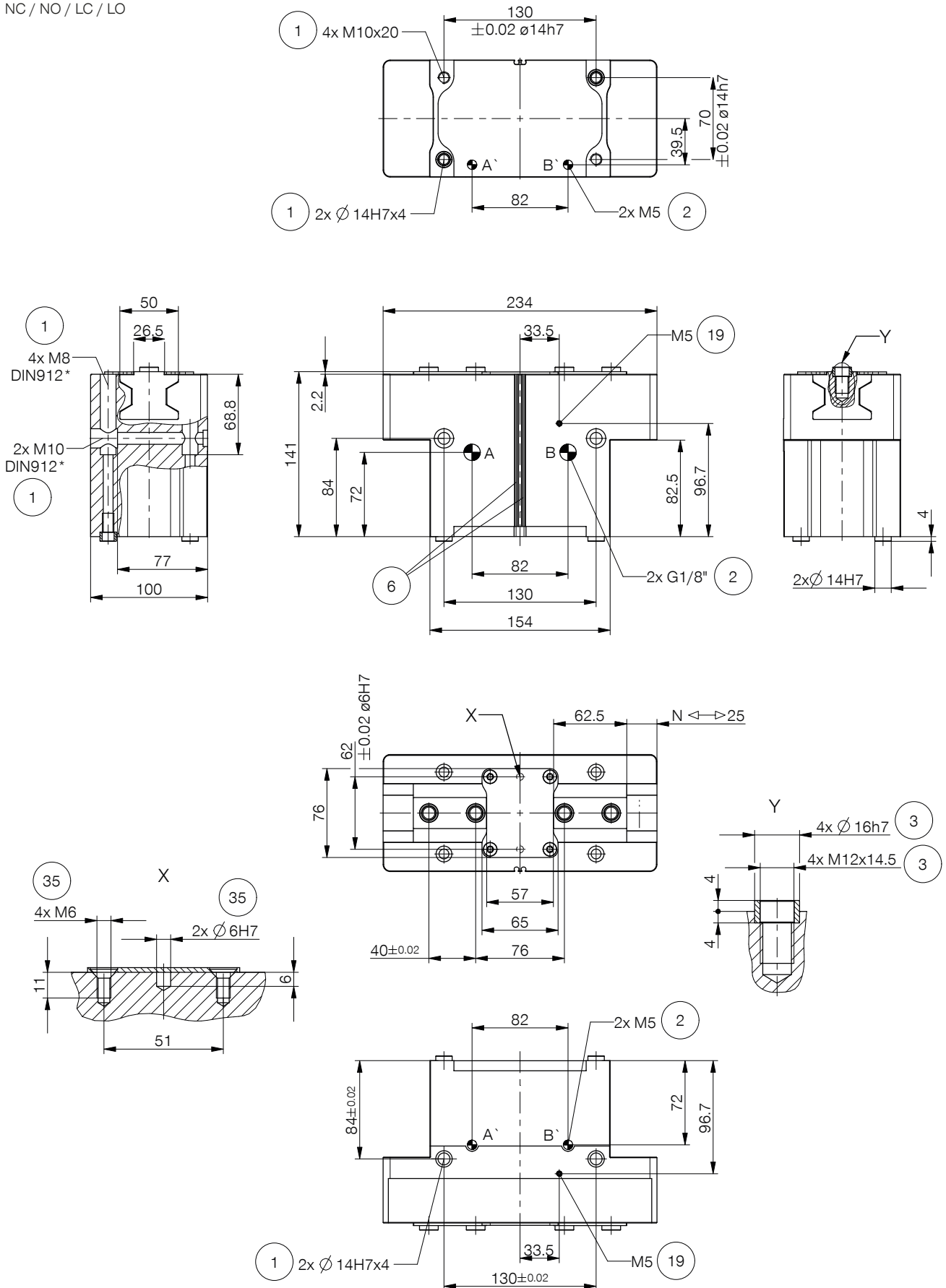

2-JAW PARALLEL GRIPPERS

INSTALLATION SIZE GPP5025AL

▶ ACCESORIES

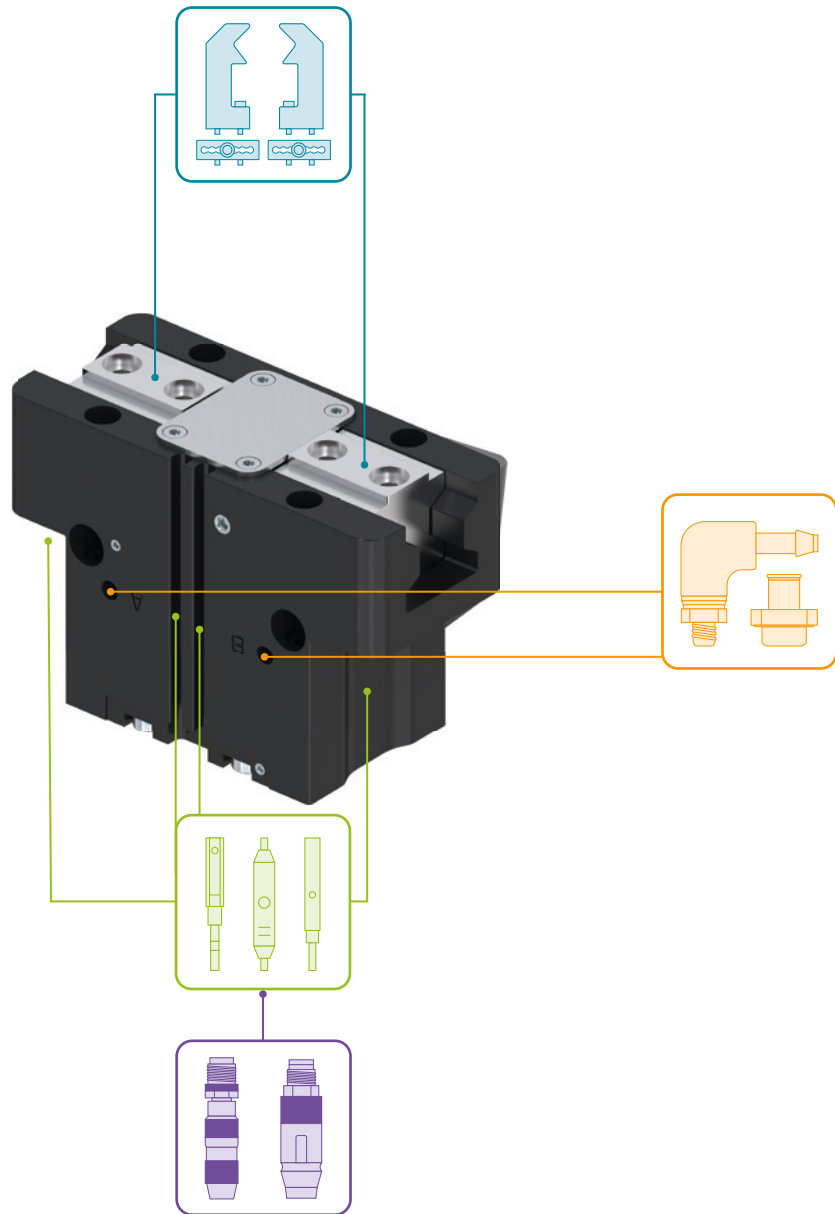

▶ INCLUDED IN DELIVERY



4 [piece]
Centering Disc

030529



2 [piece]
Centering Disc

019387

▶ RECOMMENDED ACCESSORIES



GRIPPING COMPONENTS

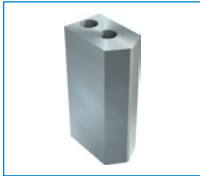

UB5025AL
Universal jaw aluminium



UB5025ST
Universal jaw steel



EB5025AL
Aluminum adjustment jaw



EB5025ST
Steel adjustment jaw

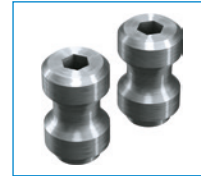

WB5025L
Changeable jaw, loose-part-set



WB5025F
Changeable jaw, fix-part



ENERGY SUPPLY



WV1-8X8
Angled Fittings - Quick Connect Style



DEV08
Quick Exhaust Valve



DSV1-8
Pressure safety valve



DSV1-8E
Pressure safety valve with quick exhaust



SENSORS

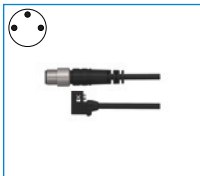

MFS01-S-KHC-P1-PNP
Magnetic field sensor angled, cable 0.3 m - M8 connector



MFS02-S-KHC-P1-PNP
Magnetic field sensor straight, cable 0.3 m - M8 connector



MFS01-S-KHC-P2-PNP
2-point sensor angled, cable 0.3 m - M8 connector



MFS02-S-KHC-P2-PNP
2-point sensor straight, cable 0.3 m - M8 connector

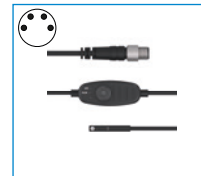

MFS02-S-KHC-IL
Straight position sensor, cable 0.3 m - M8 plug



CONNECTIONS / OTHER

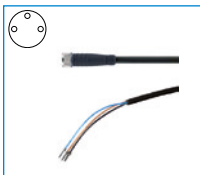

KAG500
Plug-in connector Straight Cable 5m - female connector M8

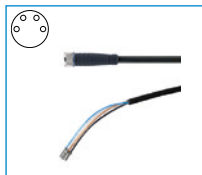

KAG500B4
Plug-in connector Straight Cable 5m - female connector M8

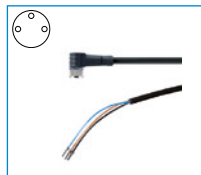

KAW500
Plug-in connector Angled Cable 5m - female connector M8



S8-G-3
Plug-in connector customizable Straight - male connector M8



S8-G-4
Plug-in connector customizable Straight - male connector M8

2-JAW PARALLEL GRIPPERS

SERIES GPP5000AL FUNCTIONAL DESCRIPTION



GRIPPING COMPONENTS

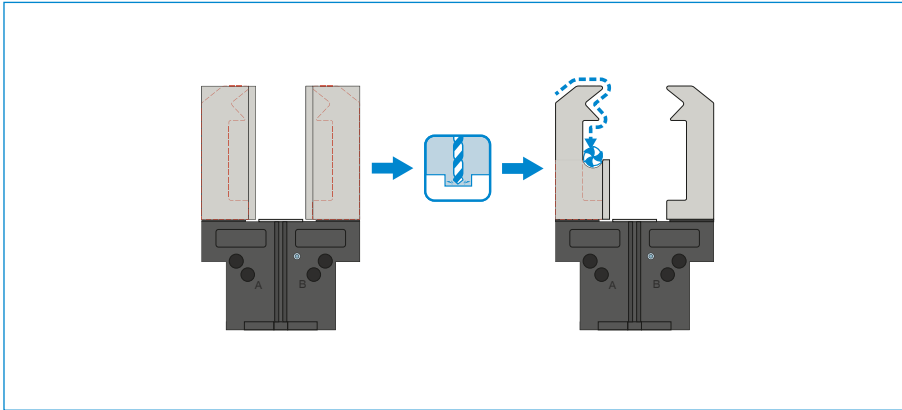

Universal jaws – UB5000

Can be used immediately or for individual reprocessing

The gripper blanks are available in aluminum (AL) and steel (ST) versions and are installed directly on the gripper using the screws in the scope of delivery. The fits for the centering sleeves are already in place for this purpose. One universal jaw is required for each gripper jaw.

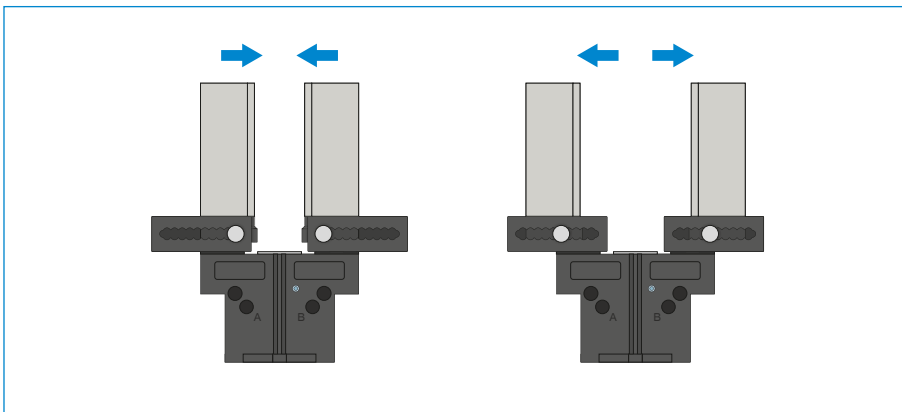

Adjustment jaws – EB5000

For tool-free adaptation of the gripper range

By manually activating the locking mechanism, which is pre-tensioned by a spring, the adjustment jaw can be moved within a grid of detent notches that has a number scale. Depending on the forces and torques that apply, the adjustment jaws are available in aluminum (AL) and steel (ST) versions. One adjustment jaw is required for each gripper jaw.

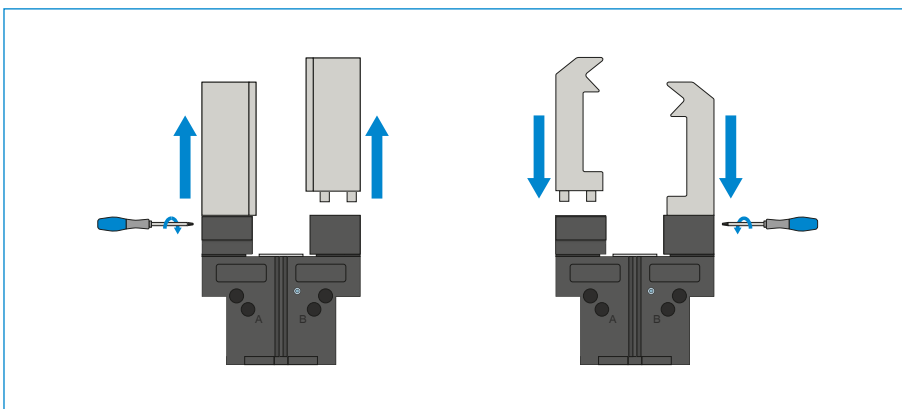

Interchangeable jaws – WB5000

Enable fast change of individual gripper fingers

For each gripper jaw, a fixed part and at least one loose part set is needed, depending on the number of gripper fingers to be changed. Manual locking via the Torx wrench included in the scope of delivery of the fixed part can take place from two sides.



THE GRIPPING COMPONENTS CAN BE COMBINED!

The gripper components listed above can be combined with each other and are compatible with the various series of the 5000 gripper family.



ENERGY SUPPLY

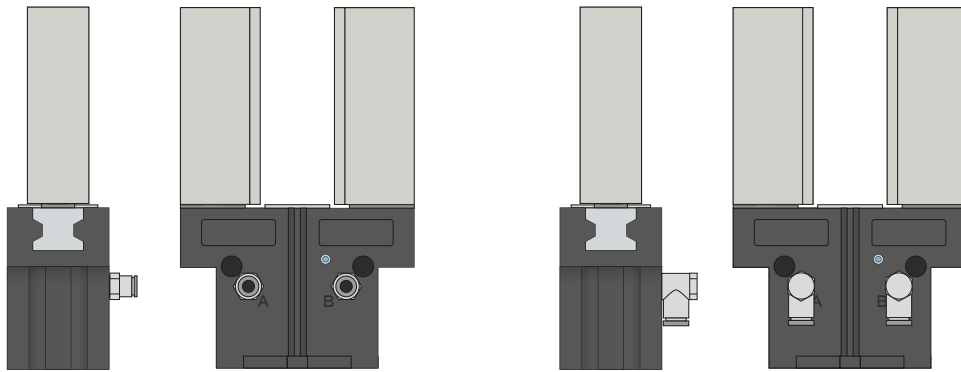

Pneumatic threaded connections

Available in straight and angled design. Can be chosen freely depending on the space conditions or installation situation.

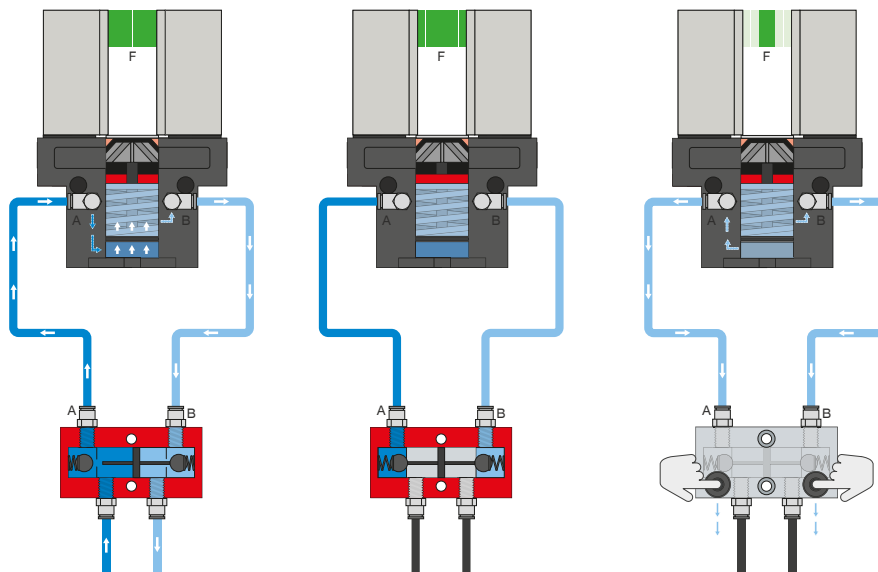

Pressure safety valve – DSV

Ensures safe retention of force and position if the system pressure drops

The integrated double check valve, which can be unlocked, retains the system pressure of the gripper in case of EMERGENCY STOP. To ensure the function, the valve must be installed as close to the gripper's air connection as possible. In variant E, two pushbuttons are installed that allow for controlled bleeding of the gripper.

2-JAW PARALLEL GRIPPERS

SERIES GPP5000AL FUNCTIONAL DESCRIPTION



ENERGY SUPPLY

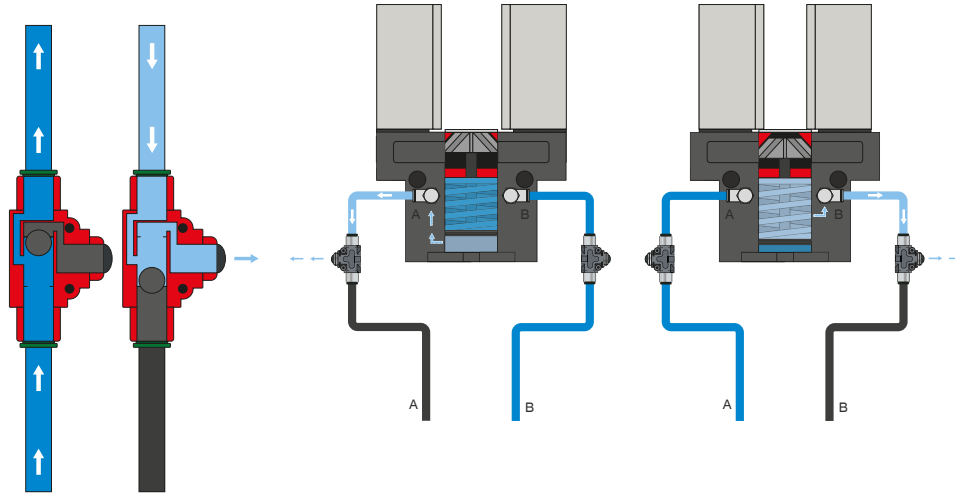

Quick exhaust valve – DEV

For rapid bleeding of the compressed air and preventing back pressure

The inline valves make a faster cycle time possible and prevent the formation of condensate in grippers with a small cylinder volume. To ensure the function, the valve must be installed as close to the gripper's air connection as possible.



SENSORS

MFS02

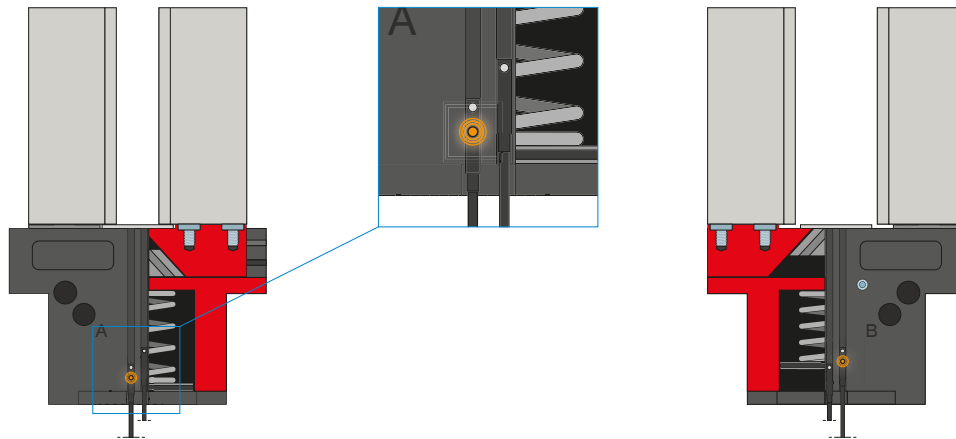

MFS01

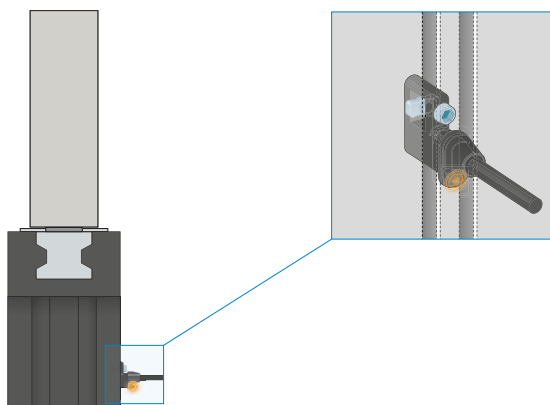

1-point magnetic field sensors – MFS

For non-contact sensing of the piston position

These sensors are installed in the C-groove of the gripper and detect the magnet attached to the piston of the gripper. To ensure use in a wide variety of space conditions, the sensors are available in two variants. While the horizontal MFS02, with straight cable outlet, disappears into the C-groove of the gripper almost completely, the vertical MFS01 is taller, but has a cable outlet that is offset at an angle of 90°. The variants are available in versions with 5 m cables with exposed leads and 0,3 m cable with connector.

2-JAW PARALLEL GRIPPERS

SERIES GPP5000AL FUNCTIONAL DESCRIPTION



SENSORS

MFS02

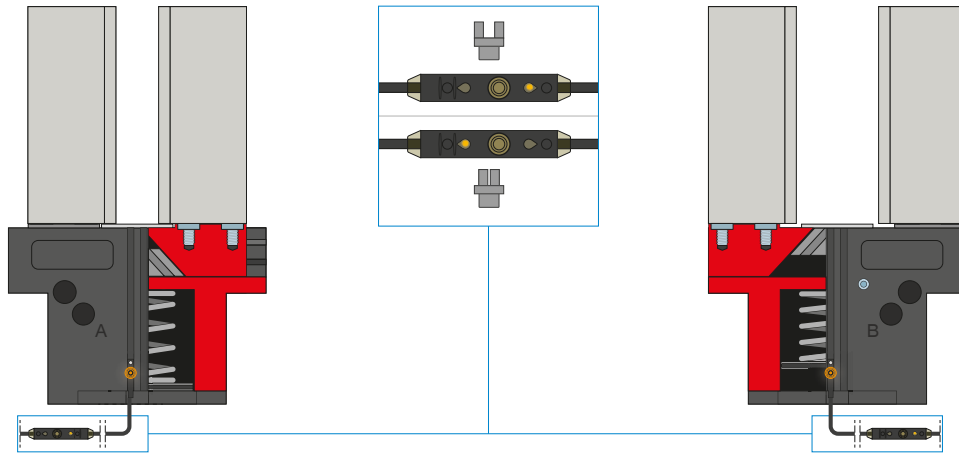

2-point magnetic field sensors - MFS

With two freely programmable switching points

Using the programming unit integrated in the cable, two switch points can be freely defined for this sensor. To do so, the sensor is clamped in the C-groove, the gripper approaches position one and the position is taught in using the teach button. Afterwards, the second position is approached with the gripper and programmed. To ensure use in a wide variety of space conditions, the sensors are available in two variants. While the horizontal MFS02, with straight cable outlet, disappears into the C-groove of the gripper almost completely, the vertical MFS01 is taller, but has a cable outlet that is offset at an angle of 90°. The sensors are available in versions with 5 m cables with exposed leads and 0,3 m cable with connector.



CONNECTIONS / OTHER



Plug-in connectors

For extending and fabricating the connection lines for the sensors

Cables with a length of 5 m with exposed leads are available. Depending on the specific needs, the cables can be shortened or fabricated with connectors in sizes M8 and M12.



CONNECTIONS / OTHER

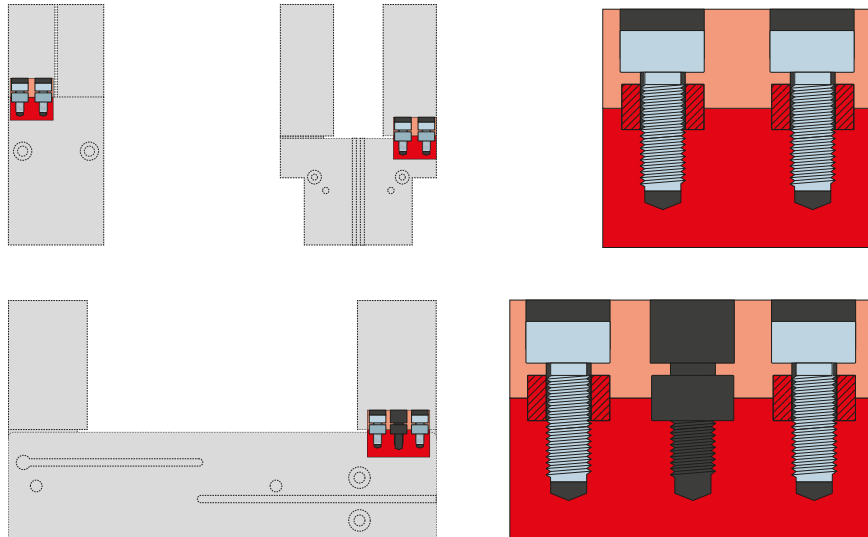

Centering sleeves

For defined position measurement of the gripper fingers

The centering sleeves are inserted into the fits of the gripper jaws to define the position of the gripper fingers. The centering sleeves are comparable to a pin connection.

2-JAW PARALLEL GRIPPERS

SERIES GPP5000AL GRIPPER FINGER LENGTH



MAXIMUM GRIPPER FINGER LENGTH

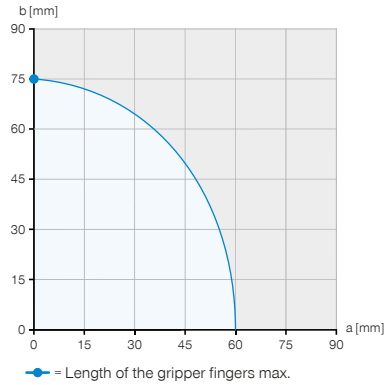
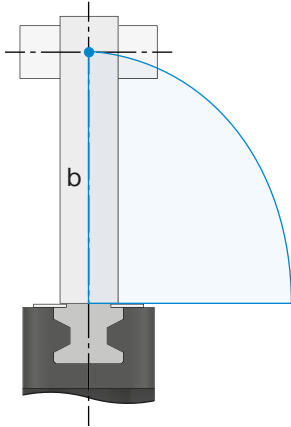

Example 1

Vertical force application point

$a = 0 \text{ mm}$

$b = 75 \text{ mm}$

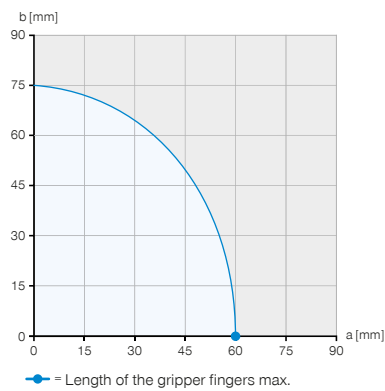
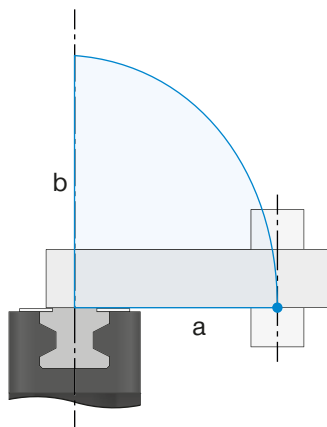

Example 2

Horizontal force application point

$a = 60 \text{ mm}$

$b = 0 \text{ mm}$

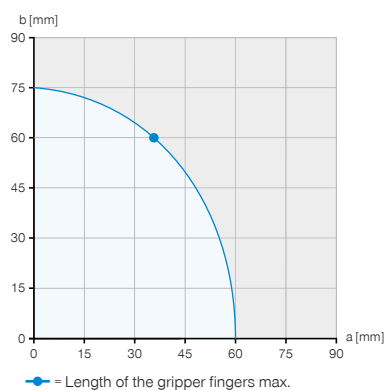
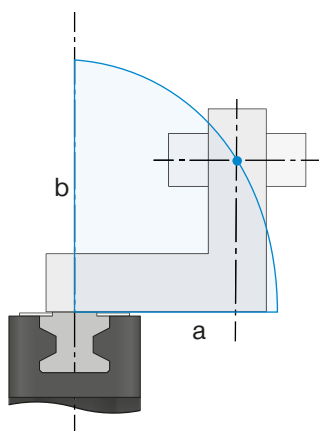

Example 3

Maximum permissible projection

$a = 37 \text{ mm}$

$b = 60 \text{ mm}$

The examples show the maximum horizontal (a) and vertical (b) gripper finger length using the example of a GPP5004N-AL-A, which is represented by the blue area.



GRIPPING FORCE AS A FUNCTION OF GRIPPER FINGER LENGTH

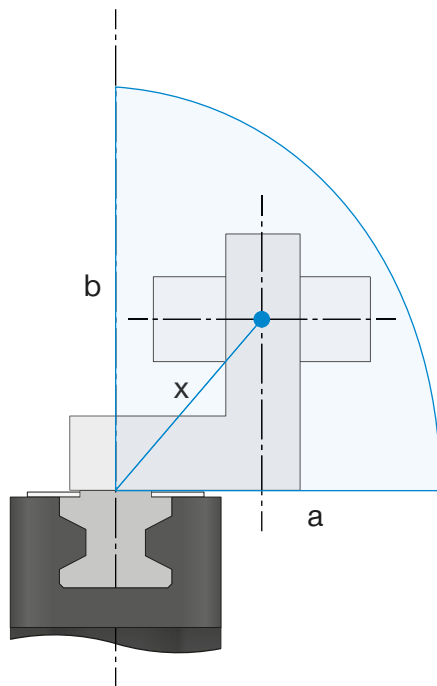

► Gripping force diagram

Shows the arithmetic total of the individual forces that occur on the gripper fingers, depending on the gripper finger length

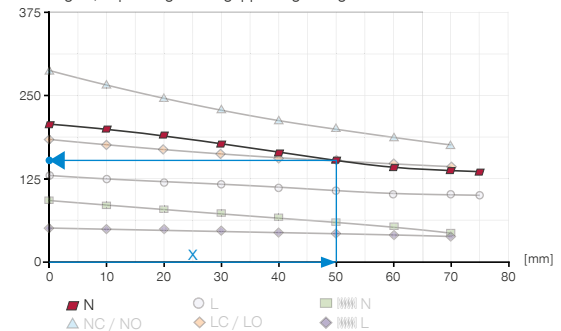

Example 4

Resulting gripper finger length for determining the gripping force

a = 30 mm

b = 40 mm

$$x = \sqrt{30^2 + 40^2} = 50 \Rightarrow 145 \text{ N}$$



GUIDE CHARACTERISTICS

Steel / aluminum guide and steel / steel guide in comparison

In general, the maximum possible length of gripper fingers of a steel / aluminum guide is lower in comparison to the steel / steel guide, due to the lower yield point of aluminum. While the maximum gripper finger length in the horizontal (a) and vertical (b) direction can be fully utilized for the steel / steel guide, the maximum gripper finger length that is specified in the technical data for the steel / aluminum guide is reduced by 20% at a horizontal (a) projection. The lower efficiency of a steel / aluminum guide also leads to a higher decrease in gripping force at an increased gripping finger length and to a reduction in service life as a result of a lower resistance to wear.

Steel / aluminum guide

Steel / aluminum guides are very common worldwide. They are available in many different forms and are installed in virtually all commercially available grippers from an extremely wide variety of manufacturers. The steel / aluminum grippers from Zimmer Group are available as AL variants of the tried-and-tested 5000 Series. Their designs are geared toward the important aspects and they are very cost-effective.

Steel / steel guide

Steel / steel guides are the best and first choice wherever durability and robustness are essential. The Steel Linear Guide from Zimmer Group is also clearly distinguished from a steel / aluminum guide thanks to its exclusive design featuring higher material characteristics.

Steel Linear Guide – Added value in detail

- + Steel in steel guide
- + IP64 and up to IP67 (with sealing air) in the protector version
- + Corrosion protected
- + Up to 30 million maintenance-free cycles (max.)