

# MOTORSPINDEL

## HF145-001-003

### ► PRODUKTVORTEILE

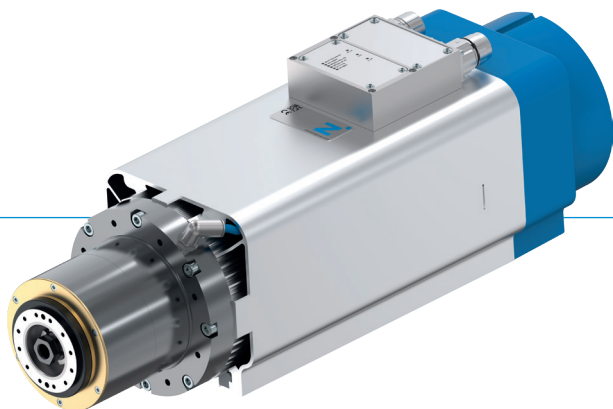

- **Nennleistung S1: 11,8 kW**  
**Nenn Drehmoment S1: 9,6 Nm**  
**max. Drehzahl: 24.000 rpm**
- Luftkühlung durch Elektrolüfter
- IO-Link Kommunikation
- Als Aggregateträger konzipiert
- Höchste Performance durch Verwendung von Hybridlager
- Geeignet für die Bearbeitung von Holz, Kunststoff, Leichtmetall und Composites

### ► AUSSTATTUNG



Konusreinigung der  
Werkzeugschnittstelle



Labyrinthdichtung



Überwachung Werkzeugaufnahme



Sperrluft



Drehzahlüberwachung



Automatischer Werkzeugwechsel



IO-Link

### ► OPTIONEN



Schnittstelle für C-Achse



Beschleunigungssensor



Vektorregelbar / Rückführung



Manuelle Werkzeugfreigabe Push  
Button



Schnittstelle für Aggregate



Roboter Wechseinheit

### ► ZUBEHÖR



Frequenzumrichter

Seite 41



Bedieneinheiten

Seite 41



Adapter  
Frequenzumrichter

Seite 41



Leistungsleitungen

Seite 43



Signalleitungen

Seite 43

## ▶ TECHNISCHE DATEN

### ▶ HF145-001-003

Asynchronmotor mit drei Phasen, 4-polig

<b>Nennleistung S1 [kW]</b>	11,8
<b>Nenndrehmoment S1 [Nm]</b>	9,6
<b>Nennstrom S1 [A]</b>	25,0
<b>Nennzahl [1/min]</b>	11,780
<b>Drehzahl max. [1/min]</b>	24.000
<b>Werkzeugschnittstelle</b>	HSK-F63
<b>Motortechnologie</b>	Asynchron
<b>Polzahl</b>	4
<b>Löseinheit</b>	Pneumatisch
<b>Kühlung</b>	Elektrolüfter
<b>Gewicht [kg]</b>	32

### ▶ Belegungsplan

	Anschlüsse
<b>A</b>	Werkzeug lösen
<b>AZ</b>	Werkzeug spannen
<b>KR</b>	Konusreinigung
<b>SPL</b>	Sperrluft
<b>XD1</b>	Leistungs- und Signalanschluss
<b>XG2</b>	Signalanschluss

