

# CLAMPING ELEMENT | MANUAL

## HKR1600A

### ▶ PRODUCT ADVANTAGES

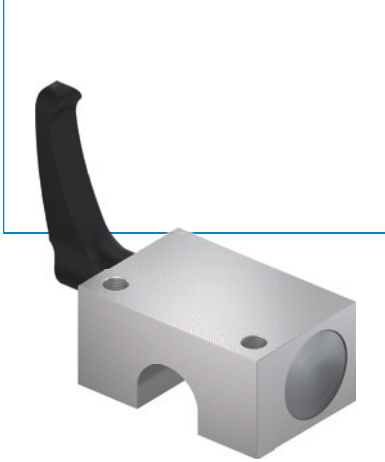

- ▶ **Independent of the manufacturer**  
For circular guides and shaft guides
- ▶ **Tool-free opening and closing (bi-stable)**  
By turning the clamping lever
- ▶ **Maintenance free**  
50,000 static clamping cycles

### ▶ TECHNICAL DETAILS



- ① **Circular guide**
  - Compatible with circular and shaft guides
- ② **Clamping lever made from plastic**
  - Freely adjustable (release by lifting)
- ③ **Clamping jaw**
  - The floating bearings guarantee symmetrical application of force
- ④ **Housing**

### ▶ INFORMATION ON THE PRODUCTS

APPLICATION SCENARIOS

- ▶ **Table traverses in wood industry**
- ▶ **Adjustment of width in plastics processing**
- ▶ **Positioning of optic instruments and measuring tables**

FURTHER INFORMATION

- ▶ **Special variants on request, e.g.**
  - Operation using DIN 912 Allen screws
  - Extended clamping lever
  - made of stainless steel

## ► TECHNICAL DRAWINGS

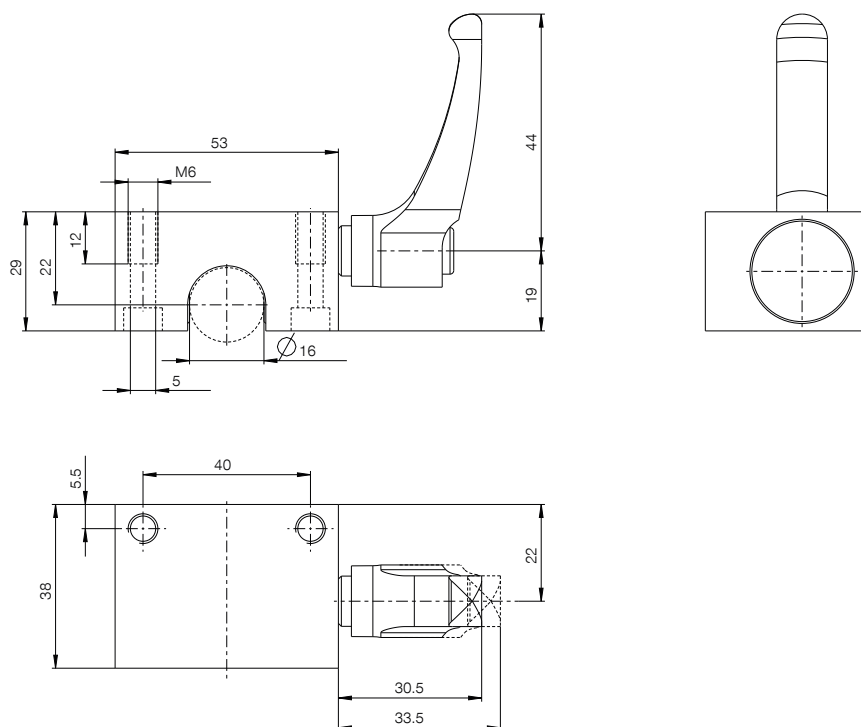

## ► TECHNICAL DATA

Order no.	HKR1600A
Operation	manual
Holding force [N]	1200
Theoretical holding force ( $\mu=0,1$ ) [N]	1,500
B10d value	50,000
Positioning accuracy +/- [mm]	0,02
Operating temperature [°C]	-10 ... +70
Weight [kg]	0.4
Shaft Ø [mm]	16
Function	Clamping
Condition	N (bistable) remains in current position
Installation direction	from above
Tightening torque [Nm]	5.00
Certifications	LABS / REACH / RoHS

Schematic drawing. General tolerances in accordance with DIN ISO 2768 T1-1/T2-H. Edges in accordance with ISO 13715. The element may only be used in the axial direction of movement. For rotational use, clarification with the technical department is required. Element has no guiding properties. Guidance must be provided externally. The holding force is the maximum force that can be applied in the axial direction. Each clamping and braking element is tested in a 100% inspection before delivery for the specified holding forces on a hardened round rail with a lightly oiled lubricating layer (ISO-VG 68). The use of other lubricants or rail coatings can influence the coefficient of friction. The operating instructions must be observed before commissioning. We reserve the right to make technical changes in the course of further development. The latest and further data can be found online and in the operating instructions at [www.zimmer-group.com](http://www.zimmer-group.com).