

TOOL CHANGERS

SERIES HWR2000

▶ PRODUCT ADVANTAGES

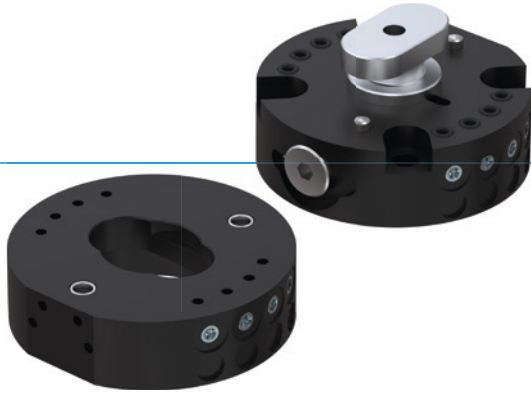

▶ **Change in seconds**

Reduce your start up costs and minimise downtimes by changing your tool in seconds

▶ **Integrated air transfer system**

For supplying pneumatic actuators. Additional media can be transmitted using optional energy elements.

▶ **Includes loss protection**

Undesired falling of work pieces is eliminated - this means the highest safety for man and machine

▶ THE BEST PRODUCT FOR YOUR APPLICATION



▶ **Our products welcome the challenge!**

Extreme conditions, all over the world—our tried and tested components and systems give you endless possibilities.

Find the best product for your specific use:

www.zimmer-group.com

► BENEFITS IN DETAIL

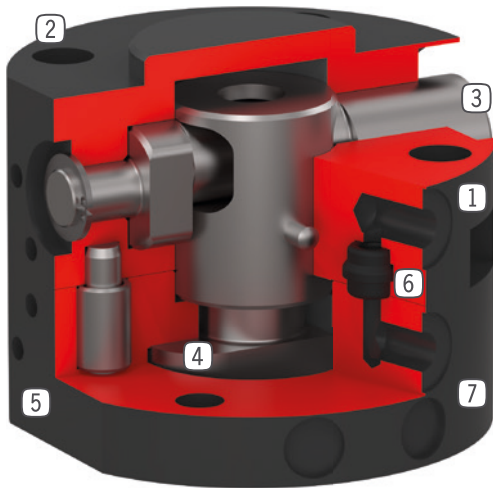

- ① **Fix part**
- For robot side assembly
- ② **Robot flange**
- partial mounting circle in accordance with EN ISO 9409-1
- ③ **Eccentric locking bolt**
- with spring supported snap in function
- ④ **Locking bolt**
- adapted to the clamping sleeve
- ⑤ **Mounting for energy element**
- ⑥ **Integrated air feed-through**
- Air / vacuum transfer
- Hoseless control possible
- ⑦ **Loose part**
- For tool side assembly

► TECHNICAL DATA

Installation size	Connecting flange according EN ISO 9409-1	Pneumatic energy transfer	Electrical energy transfer
		[Quantity]	
HWR2031	TK 31.5	4	optional
HWR2040	TK 40	4	optional
HWR2050	TK 50	8	optional

► FURTHER INFORMATION IS AVAILABLE ONLINE



All information just a click away at: www.zimmer-group.com. Find data, illustrations, 3D models and operating instructions for your installation size using the order number for your desired product. Quick, clear and always up-to-date.

TOOL CHANGERS

INSTALLATION SIZE HWR2040

▶ PRODUCT SPECIFICATIONS

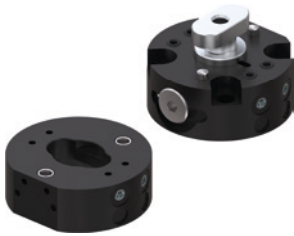

▶ Variable installation position

Shows the maximum handling weight depending on acceleration and lever arm. Does not replace the technical design.

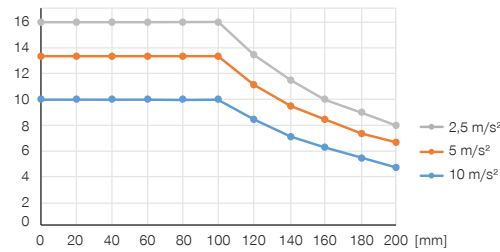

▶ Forces and moments

Shows static forces and moments which may impact on the tool changer when locked.

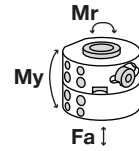

Mr [Nm]	55
My [Nm]	50
Fa [N]	1200

▶ RECOMMENDED ACCESSORIES



ENERGY SUPPLY



GVM5
Straight Fittings - Quick Connect Style



CONNECTIONS / OTHER



Energy elements and accessories for tool changers

Order no.	► Technical data	
	HWR2040F	HWR2040L
Connecting flange according EN ISO 9409-1	TK 40	TK 40
Pneumatic energy transfer [Quantity]	4	4
Flow per connector [l/min]	150	150
Electrical energy transfer	optional	optional
Self locking mechanism when locking	mechanical	mechanical
Locking stroke [mm]	4	
Repetition accuracy in Z [mm]	0.01	0.01
Repetition accuracy in X, Y [mm]	0.02	0.02
Nominal operating pressure [bar]	6	6
Operating temperature [°C]	5 ... +80	5 ... +80
Moment of inertia [kgcm ²]	0.33	0.26
Weight [kg]	0.15	0.071

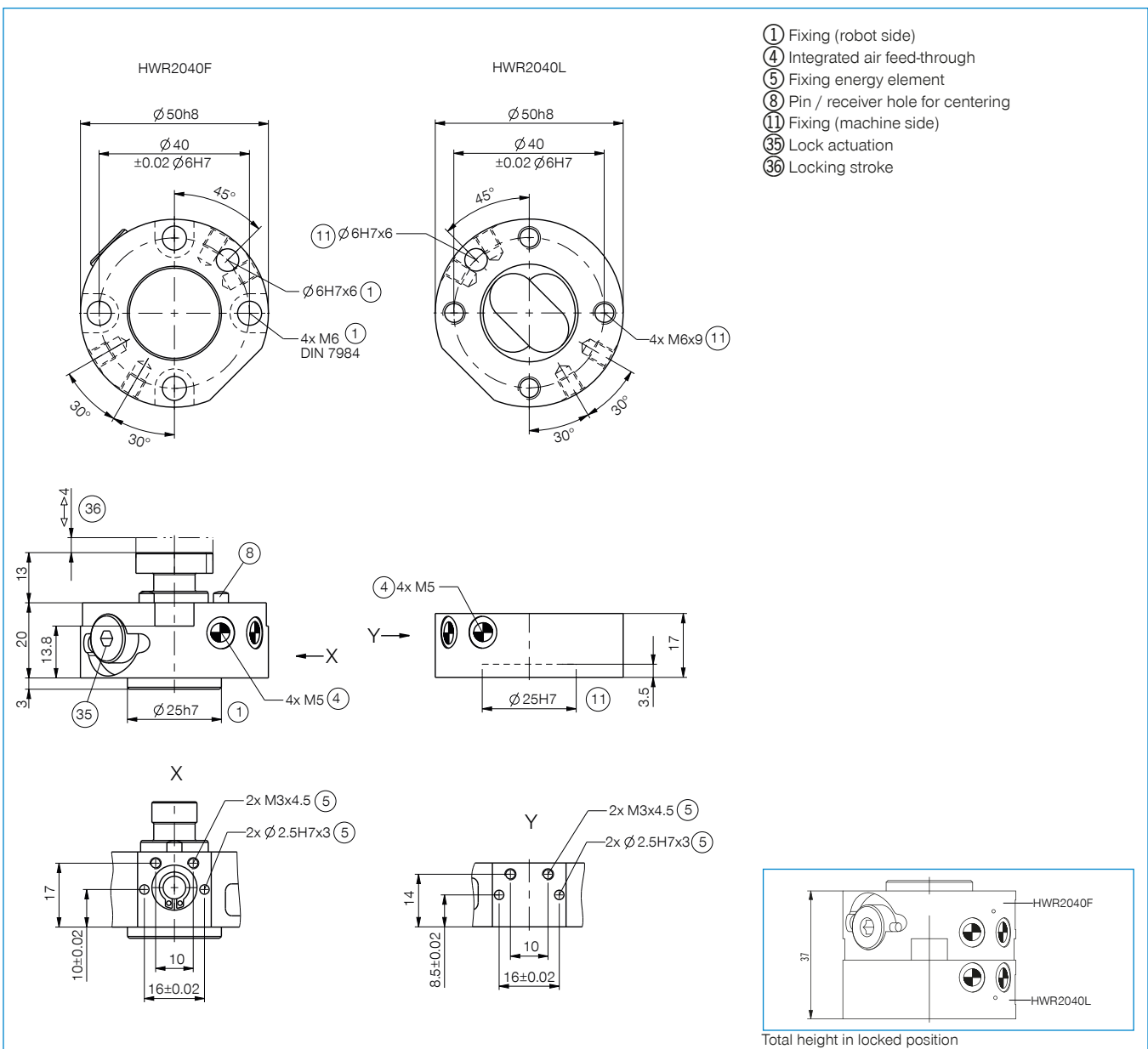

ENERGY ELEMENTS FOR TOOL CHANGER

SIZES HWR2031 / HWR2040 / HWR2050

▶ CONNECTION DIAGRAM

