

INTERNAL GRIPPER

SERIES LGS

▶ PRODUCT ADVANTAGES



▶ Concentration on the essentials

The most economic type of gripping: This is how you reduce your production costs





▶ Individually machinable clamping jaws

You have never adjusted a gripper to your application this quickly and easily

▶ Direct drive

The control system with only one pneumatic line reduces installation effort and interference contours

▶ SERIES CHARACTERISTICS

Installation size	Version	
LGXX-XX	-	V
 Collet Chuck	•	
 Extended collet chuck		•
 Maintenance free	•	•
 IP 40	•	•



► BENEFITS IN DETAIL

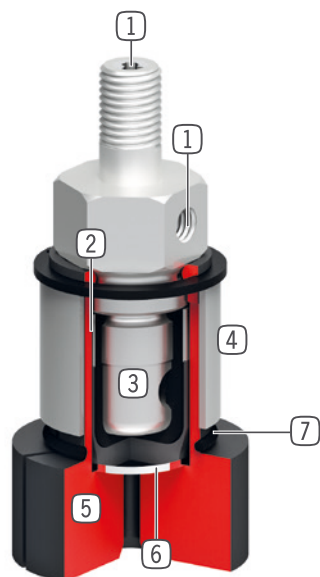

- ① **Energy supply**
 - axial and radial possible
- ② **Protective membrane**
 - between collet chuck and function membrane
- ③ **Direct drive with membrane**
 - only one pneumatic line required
- ④ **Stroke limit**
 - prevents damage by overstretching with empty strokes
- ⑤ **Collet chuck**
 - for individual machining
- ⑥ **Steel protective cover**
 - protects the membrane against puncturing
- ⑦ **O-ring for backstroke**
 - gripper close movement after venting

► TECHNICAL DATA

Installation size	Total stroke in Ø [mm]	Gripping moment [Nm]	Weight [kg]	IP class
LG4-20	1.0	0,5	0,075 - 0,115	IP40
LG20-30	1.0	2	0,16 - 0,29	IP40
LG30-50	1.0	3	0,46	IP40

► FURTHER INFORMATION IS AVAILABLE ONLINE



All information just a click away at: www.zimmer-group.com. Find data, illustrations, 3D models and operating instructions for your installation size using the order number for your desired product. Quick, clear and always up-to-date.

INTERNAL GRIPPER

INSTALLATION SIZE LG30-50

▶ PRODUCT SPECIFICATIONS



▶ INCLUDED IN DELIVERY



1 [piece]
Collet Chuck
DST30500

▶ RECOMMENDED ACCESSORIES



ENERGY SUPPLY



GVM5
Straight Fittings - Quick Connect Style

Order no.	Technical data
	LG30-50
Total stroke in Ø [mm]	1.0
Gripping diameter min. [mm]	6.0
Gripping moment in opening [Nm]	3.0
Machining length of the collet max. [mm]	11
Closing time [s]	0.1
Opening time [s]	0.1
Operating pressure min. [bar]	4
Operating pressure max. [bar]	6
Nominal operating pressure [bar]	6
Operating temperature min. [°C]	5
Operating temperature max. [°C]	+60
Air volume per cycle [cm³]	5
Protection to IEC 60529	IP40
Weight [kg]	0.47

