

CLAMPING ELEMENT | PNEUMATIC

MKR2500A

▶ PRODUCT ADVANTAGES



- ▶ **Independent of the manufacturer**
For circular guides and shaft guides
- ▶ **Energize to close (NO)**
Closing with pressure
- ▶ **high durability**
5 million static clamping cycles

▶ TECHNICAL DETAILS

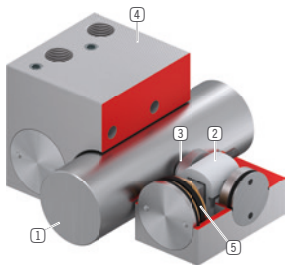

- ① **Circular guide**
 - Compatible with circular and shaft guides
- ② **Wedge-type gear**
 - Power transmission between piston and clamping jaw
- ③ **Clamping jaw**
 - Pressed at the circular guide
- ④ **Housing**
- ⑤ **Pneumatic piston**
 - The piston moves the wedge-type gear longitudinally

▶ INFORMATION ON THE PRODUCTS

APPLICATION SCENARIOS

- ▶ **Fixing of vertical axes**
- ▶ **Positioning of lifting units**
- ▶ **Clamping of machine tables**

FURTHER INFORMATION

- ▶ **Special variants on request, e.g.**
 - With proximity switch monitoring
 - With additional air connection (from above, from the front)

► TECHNICAL DRAWINGS

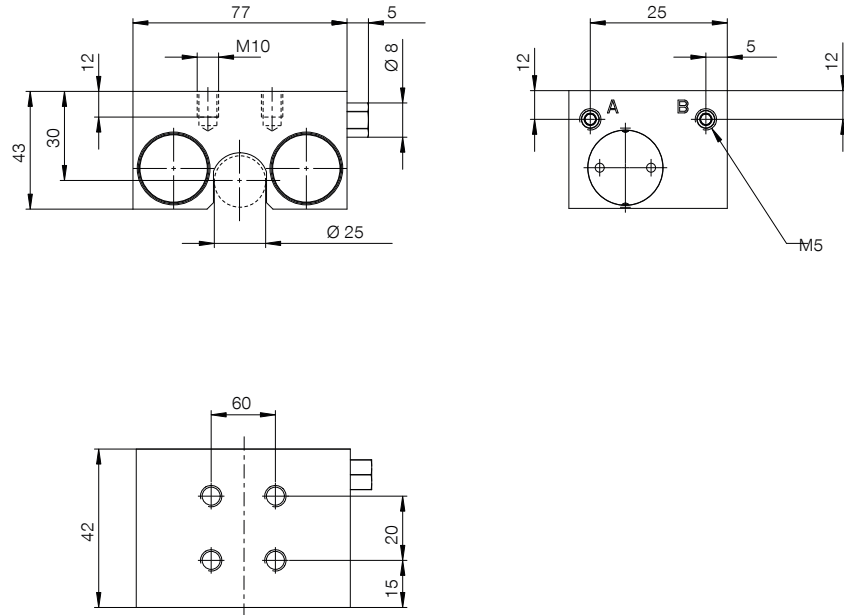

Ⓐ Vent filter (one-sided)

Ⓑ Connection closing (both sides possible, only one connection necessary)

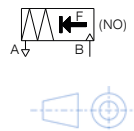

► TECHNICAL DATA

Order no.	MKR2500A
Operation	pneumatic
Holding force [N]	1200
Theoretical holding force ($\mu=0,1$) [N]	1,500
PLUS connection possible	No
Operating pressure [bar]	2 ... 6.5
Nominal operating pressure [bar]	6
B10d value	5,000,000
Positioning accuracy +/- [mm]	0,02
Opening time [s]	0.025
Closing time [s]	0.01
Operating temperature [°C]	-10 ... +70
Weight [kg]	0.72
Shaft \varnothing [mm]	25
Function	Clamping
Condition	NO (Normally Open) open without pressure
Installation direction	from above
Air volume per cycle [cm ³]	10
Certifications	LABS / REACH / RoHS

Schematic drawing. General tolerances in accordance with DIN ISO 2768 T1-f/T2-H. Edges in accordance with ISO 13715. The element may only be used in the axial direction of movement. For rotational use, clarification with the technical department is required. Element has no guiding properties. Guidance must be provided externally. The holding force is the maximum force that can be applied in the axial direction. Each clamping and braking element is tested in a 100% inspection before delivery for the specified holding forces on a hardened round rail with a lightly oiled lubricating layer (ISO-VG 68). The use of other lubricants or rail coatings can influence the coefficient of friction. The operating instructions must be observed before commissioning. We reserve the right to make technical changes in the course of further development. The latest and further data can be found online and in the operating instructions at www.zimmer-group.com.