

EXTERNAL GRIPPER

SERIES RG

▶ PRODUCT ADVANTAGES

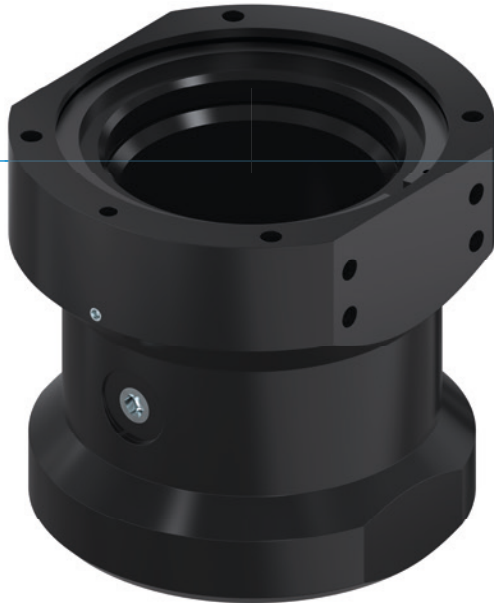

▶ **Surface protection with rubber knobs**

Continuously protect the surface of your workpieces and minimise rejections in the process

▶ **Secure hold**

The coefficient of friction ensures your workpiece stays held reliably, even under high dynamics

▶ **Direct drive**

The control system with only one pneumatic line reduces installation effort and interference contours

▶ SERIES CHARACTERISTICS

Installation size

RGXX-XX



Maintenance free



IP67





► BENEFITS IN DETAIL

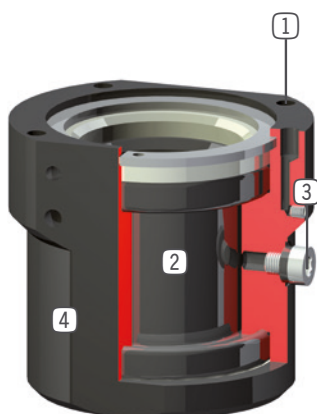

- ① **Mounting and positioning**
- ② **Drive**
 - direct via rubber membrane
- ③ **Energy supply**
 - possible from several sides
- ④ **Robust, lightweight housing**
 - Hard-coated aluminum alloy

► TECHNICAL DATA

Installation size	Gripper hole diameter	Gripping force	Weight	IP class
		[N]	[kg]	
RG0-30	0 - 28	350	0.28	IP67
RG10-60	10 - 58	1000	0.86	IP67

► FURTHER INFORMATION IS AVAILABLE ONLINE



All information just a click away at: www.zimmer-group.com. Find data, illustrations, 3D models and operating instructions for your installation size using the order number for your desired product. Quick, clear and always up-to-date.

EXTERNAL GRIPPER

INSTALLATION SIZE RG0-30

▶ PRODUCT SPECIFICATIONS



▶ RECOMMENDED ACCESSORIES



ENERGY SUPPLY



GVM5
Straight Fittings - Quick Connect Style



ENERGY SUPPLY



DEV04
Quick Exhaust Valve

Order no.	RG0-30
Gripping diameter min. [mm]	0
Gripping diameter max. [mm]	28
Gripping force in closing [N]	350
Closing time [s]	0.1
Opening time [s]	0.1
Operating pressure min. [bar]	1
Operating pressure max. [bar]	3
Nominal operating pressure [bar]	3
Operating temperature min. [°C]	5
Operating temperature max. [°C]	+80
Air volume per cycle [cm³]	5
Protection to IEC 60529	IP67
Weight [kg]	0.28

► Technical data

- ① Gripper attachment
- ② Energy supply
- ③⑧ Adapter
- ③⑨ Gripper
- Ⓐ Air connection (close)
- Ⓐ Air connection, alternative (close)

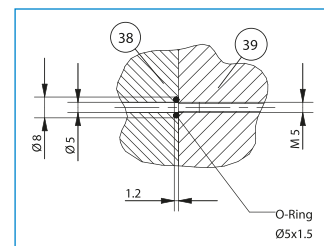

Hoseless air feed-through

