

3-JAW INTERNAL GRIPPERS

SERIES WTR2000

▶ PRODUCT ADVANTAGES

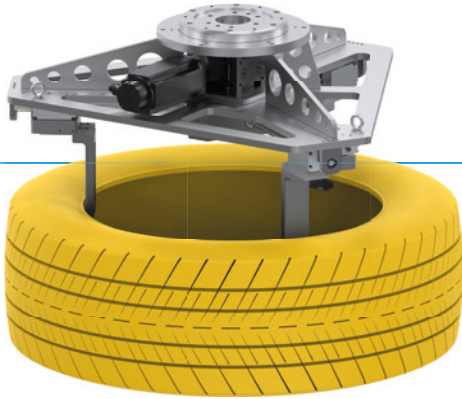

- ▶ Dynamic, strong, and robust ready-to-mount gripper on gantry or robot for finish tire handling
- ▶ Lightweight, modular industry-standard gripper provides flexibility and ease of use
- ▶ A secure and balanced grip reduces the risk of tire deformations
- ▶ Sensor mounting to verify the presence of the tire
- ▶ Can handle a wide range of tire diameters
- ▶ Useful for finished tire handling in the intermediate storage area
- ▶ Workpiece contact parts are made of stainless steel

▶ SERIES CHARACTERISTICS



Drive AC servo motor



Internal gripping



Gripper jaws are synchronized

▶ CHALLENGE AND SOLUTION

- ▶ Interface flange for standard robots and gantries with ready-to-mount solution
- ▶ High dynamics high speed with servo operated linear guide mechanism to grip tire
- ▶ Wide range of diameter and weight with keeping tire centered to prevent misalignment
- ▶ Suitable for corrosive and humid environments with stainless steel components and coated parts
- ▶ Easy maintenance with easy-to-replace parts
- ▶ Light and readily available, an economical choice for system integrators
- ▶ Low TCO for end users with low cost, high availability and proven design

▶ VARIANTS

WTR2000-156381-A

Tire gripper for finished tires
PCR tires

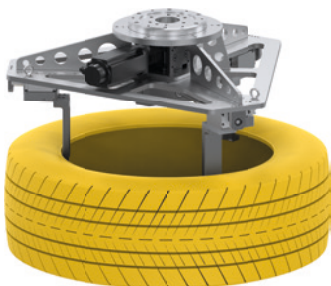

WTR2000-165197-A

Tire gripper for finished tires
TBR tires



► BENEFITS IN DETAIL

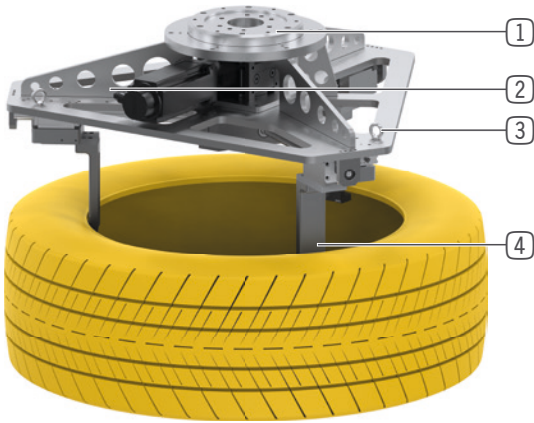

- ① **Robot flange**
- ② **Drive**
- AC servo motor
- ③ **Screw mechanism**
- ④ **Gripper jaw**
- hardened steel

► TECHNICAL DATA

Order no.	WTR2000-156381-A	WTR2000-165197-A
Type of drive *	electrical	electrical
Included in delivery	Gearbox	Gearbox
Connection	Portal	Portal
Handling principle	Grasp	Grasp
Movement type of the gripper	Palletizing mode	Palletizing mode
Gripper type	Form fit	Form fit
Gripping concept	Internal gripping	Internal gripping
Gripping points	Inner diameter	Inner diameter
Gripper jaws are synchronized	Yes	Yes
Stroke per jaw [mm]	210	180
Nominal gripping force [N]	400.0	400.0
Workpiece	PCR tires	TBR tires
Arrangement of the workpieces	Sample	Sample
Number of workpieces in the gripper	1	1
Interface to the workpiece	Steel jaw	Steel jaw
Diameter inside min. ["]	12	18
Diameter inside max. ["]	27	28
Workpiece height [mm]	400.0	460.0
Gathering workpieces	one direction	one direction
Workpiece weight max. [kg]	45	100
Certifications	LABS / REACH / RoHS	LABS / REACH / RoHS
Weight [kg]	60	72

*Please note: motor, drive and sensors are not included in the scope of supply and can be ordered separately.
For different motors, please contact Zimmer Group sales team.