

HANDLING SYSTEM FOR RIMS

Z01SYS121154

▶ PRODUCT INFORMATION

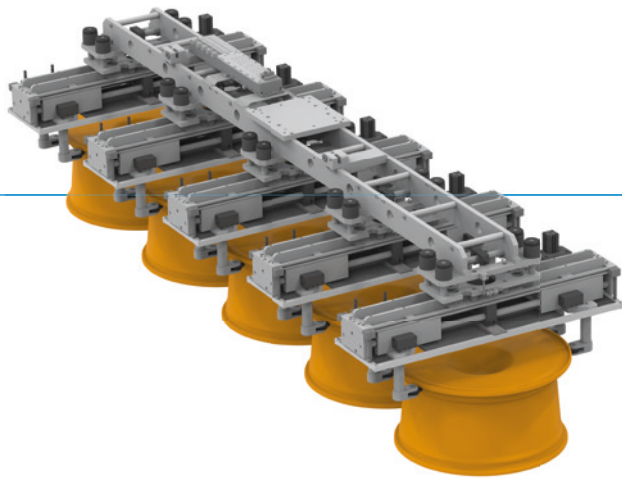

- ▶ The standard solution developed by Zimmer Group for handling automotive rims was designed to reliably handle the most common rim sizes throughout all production processes. Set-up time is kept to a minimum or eliminated entirely. Whether in machining or surface treatment, the system allows flexible configuration as a single, double or multiple gripper system.

▶ CHALLENGE

- ▶ Wide variety of parts from 14" - 24"
- ▶ Powder-coated rims/uncured
- ▶ Cycle time
- ▶ Compensation of height differences during the depositing process
- ▶ Workpiece holder

▶ SOLUTION

- ▶ Long stroke gripper with up to 220 mm stroke/jaw
- ▶ Rotating cutter disc
- ▶ Axis compensation in Z direction
- ▶ Position maintenance by means of clamping element
- ▶ Active stroke limitation for cycle time optimization

▶ WORKPIECE

- ▶ Workpiece weight 30 kg
- ▶ Diameter: 14" - 24" / 355 - 610 mm



▶ TECHNICAL DATA

Product	Rims/cylindrical components
Gripping technology	Frictional fit
Workpiece weight [kg]	5 x 30
System weight [kg]	340
Drive type	Pneumatic

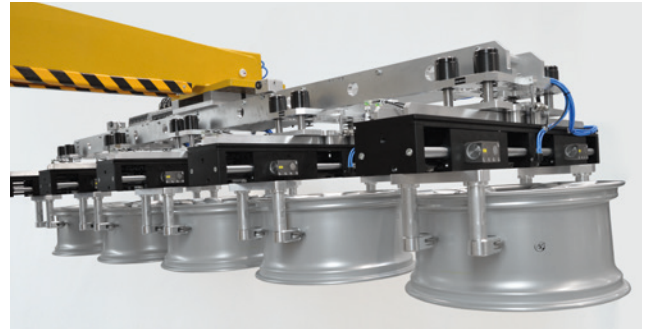

▶ FUNCTIONS IN DETAIL

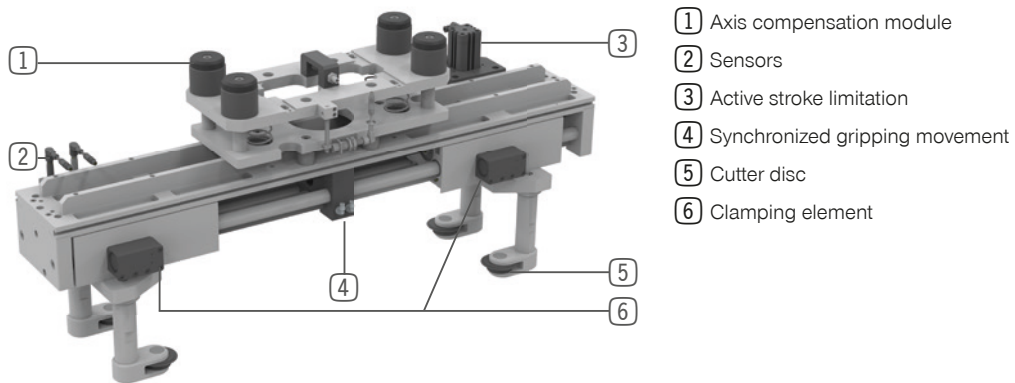

▶ MORE INFORMATION/CROSS REFERENCES

- ▶ 1-fold rim gripper
Z01SYS114166

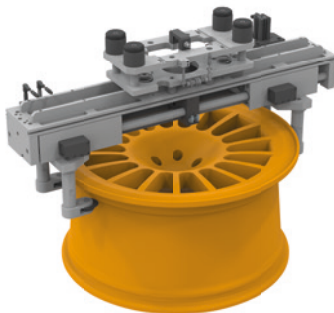

- ▶ Gripper finger variants

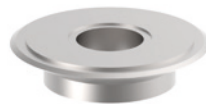

Cutter disc

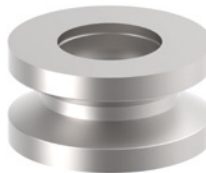

Tapered roller



Rubber roller