

INSTALLATION AND OPERATING INSTRUCTIONS



Handling technology

VEE9000-Series
Separators, electrical

THE KNOW-HOW FACTORY

1. Other valid documentation



Information:

Following documents are available at our website. Only current documents are valid at our website.

- Catalog
- drawings, performance data, information on accessories etc.
- General terms and conditions, Information about warranty

2. Intended use



Note: Separators can only be used in mint condition, with original accessories, unauthorized alterations are excluded from manufacturer's liability and it has to be within its defined parameters. Zimmer GmbH doesn't accept liability for any possible damages if intended use isn't considered.

Separators has exclusively been designed for electric application of a supply voltage of 24V. The separator is used as defined under „Proper use“ in closed rooms to separate workpieces. It is not suitable for clamping work pieces during processing and for direct interaction with perishable products.

3. Function

EA current impulse can set the integrated drive of the plunger coil ① in motion. The travel length generated in this process is conveyed to the plunger ② and produces a stroke.

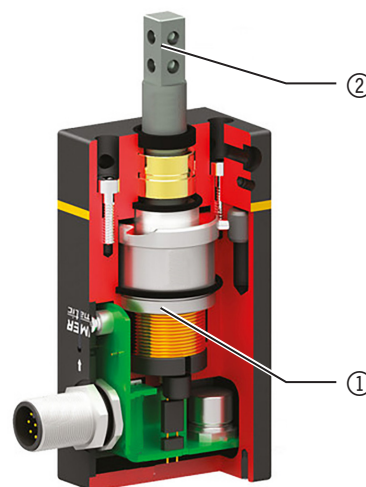

4. Personell qualification

Assembling, start-up and maintenance can only be carried out by trained staff. It is essential that these people should have read and understood the assembly instructions and handbook.

5. Assembly

5.1 Information about possible dangers when installing the separators



ATTENTION: While ignoring system failure can be caused by separators

Bevore carrying out assembly, installation and maintenance work, always switch off the power supply to the electronics

5.2 Assembly separators

Separators can be assembled on several sides according to its mounting surface specifications on evenness.

For assembling the separators following work steps have to be conducted:

- ▶ Cylinder pins have to be inserted in fit feature of the separators
- ▶ Separators has to be positioned by means of cylinder pins on the surface
- ▶ Separators has to be fastened with cylinder head screws of property class 8.8
- ▶ apply cable KAG1000B8 (plug straight) or KAW1000B8 (plug angle) has to be assembled

Data for evenness, tightening torque and screw diameter are mentioned under chapter „Technical data“ .

5.3 Assembly plunger extension

Before assembling plunger extension, weight and length has to be checked with regard to its selected separators type.

For assembling the plunger extension, the following work steps have to be performed:

- ▶ Fastening the plunger extension to the plunger via screw/nut connection



Information: Data for tightening torque, screw diameter, maximum weight and length of plunger extension are mentioned under chapter „Technical data“.

6. Start up

6.1 Drive

To use the separator, a voltage supply is required at inputs 3 and 8 (0V) as well as at input 6 (+24VDC/5A).

Input 1 (DIR) serves as the control input to activate the separator.

Input 1 (DIR) signals must remain present until a separator counter movement is required.

The energy consumption during the plunger movement is $\leq 5A$. At resting position, the energy consumption of the separator is 0.02A.

6.2 Cable configuration

PIN	Color	Function	Description
1	white	DIR	IN 24 VDC control input for extend/retract separator
2	brown	W-POS	OUT 1 signal separator extended
3	green	GND	0VDC voltage supply
4	yellow	DIAG	OUT 2 diagnostic output
5	gray	B-POS	OUT 3 signal separator retracted
6	pink	+24VDC	+24VDC / 5A voltage supply
7	blue	adjust	IN input: Set end positions
8	red	GND	0VDC voltage supply

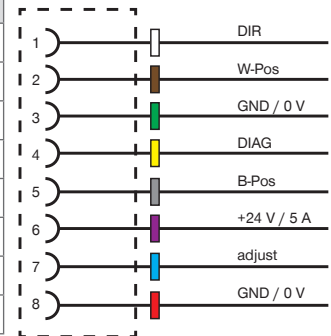

6.3 Plan of procedures

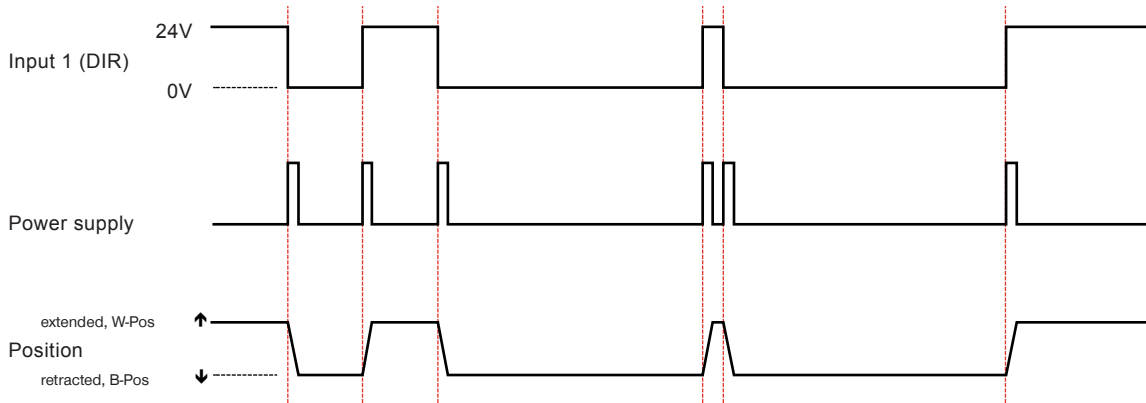

7. Maintenance

7.1 Maintenance intervals

Maintenance-free operation of the separator VEE9000-series is guaranteed for up to 30 million cycles

Maintenance intervals of 30 million cycles can be decreased in following situations:

- dirty environment
- if separators is not used according to its performance data and according to its regulations

7.2 Disassemble separators

It is recommended to maintain all products by Zimmer GmbH repair's service. If separators is assembled or dissembled unauthorized , complications may come up due to the fact that special assembling fixtures are required..

8. Troubleshooting

8.1 LED display

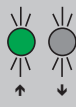
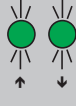
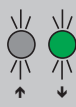

8.2 Fault diagnostics

Error	Possible causes	Troubleshooting
Temperature out of range LED display blinks 	Adaptor plate is manufactured of a material with less thermal conductivity	► Heat conduction of adaptor plate can be altered by improving materials
	Ambient temperature too high	► Sufficient air ventilation is essential
Positioning of sensor defect, no current in coil LED display blinks 	Electric power supply malfunctioning	► Supply cable has to be checked on error
		► Aligned current and voltage has to be checked
		► Separators has to be send in for inspection
Voltage out of range LED display blinks 	Electric power supply malfunctioning	► Supply cable has to be checked on error
		► Separators has to be send in for inspection
Plunger does not move	Electric power supply malfunctioning	► Supply cable has to be checked on defects. ► Versorgungsspannung und Strom prüfen.
	Damage of one or more functional parts due to overload	► Separators has to be send in for inspection
Signals in end position are not displayed	end position lies out of the pre-set range	► Calibration of the end positions via automatic running procedure
	Supply cable defective	► Supply cable has to be changed
	Magnetic source of interference	► Remove all magnetic products within 15 mm of the housing
	Integrated hall sensor defective	► Separators has to be send in for inspection

8.3 Status table VEE



Information:

Während der Bestromung der Spule und bis zur Stabilisation der Positionen, liegt kein Signal an.

Condition	output			LED display blinks	
	W-Pos	DIAG	B-Pos	W-POS ↑	B-POS ↑
Temperature outside of permitted range	I	I	0	I	0
Defective position sensor	I	I	I	I	I
Voltage outside of permitted range	0	I	I	0	I

9. Accessory / scope of delivery



Note: The function of the separators is not guaranteed while using non authorized accessories of Zimmer GmbH. Accessories of Sommer-automatic GmbH are particularly tailored to every separators.

Optional accessories can be found at www.zimmer-group.de

10. Sensor technology

10.1 Detection of the end positions

The end position sensing of the separators is preset by manufacturer. On request, the end positions can be reset with the help of an automatically running procedure.

- ▶ For this purpose, at input 7 (adjust) a signal (+24V) has to be fed in for at least 10 seconds. After 3 seconds, the procedure will start and ends after 20 cycles
- ▶ Should the signal (+24V) be interrupted during the running procedure, the new end positions are not saved in the internal control unit
- ▶ The feedback of the end positions is given via output 2 (W-POS, closed) and 5 (B-POS, open).
- ▶ This status is visualized at the separators via LED display.

10.2 LED display



8.3 Status table



Information:

There is no signal during current feed of coil and until stabilization of position.

Condition	output			LED display	
	W-Pos	DIAG	B-Pos	W-POS ↑	B-POS ↓
Separator extended	1	0	0	1	0
Separator retracted	0	0	1	0	1

11. Declaration of incorporation according to EU directive 2006/42/EG on machines (annex II 1 B)

Name and address of the manufacturer:

Zimmer GmbH
Im Salmenkopf 5
D-77866 Rheinau

We hereby state that the below mentioned imperfect machines

Type designation: Separatorss electrical

Type of designation: VEE9□□□-Series

are in accordance with essential requirements on machine directive 2006/42/EG

Nr.1.1.2., Nr.1.1.3., Nr.1.1.5., Nr.1.3.2., Nr.1.3.4., Nr.1.3.7., Nr.1.5.3., Nr.1.5.4., Nr.1.5.8., Nr.1.6.4., Nr.1.7.1., Nr.1.7.4.

Furthermore, we declare that all special technical data is according to directive's annex VII part B. We undertake to transfer electronically specific data about incomplete machines by our documentation department due to reasoned statements of the institution for market surveillance. The incomplete machine can only be commissioned if the machine or plant in which the incomplete machine is installed is according to machine requirements of EU 2006/42/EG and if the EC Declaration of Conformity is issued according to annex II 1 A.

Authorized person for compiling relevant technical data

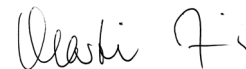

Kurt Ross	See address of manufacturer	Rheinau, den 27.01.2014	Martin Zimmer
First name urname	Address	(Date and place for issuing)	((legally binding signature Managing partners

12. Declaration of Conformity according to EU directive 2004/108/EG on Electro-magnetic Compatibility (EMC)

Name and address of the manufacturer:

Zimmer GmbH
Im Salmenkopf 5
D-77866 Rheinau

We hereby state that the products mentioned below

Type designation: Vereinzeler, elektrisch

Type of designation: VEE9□□□-Serie

are in accordance with following norms and normative documents of the EMV directives 2004/108/EG

- EN 61000-6-2: 2005 Electro-magnetic Compatibility (EMC) – part 6-2: generic standards; immunity, industrial sector
- EN 61000-6-4: 2007 Electro-magnetic Compatibility (EMC) – part 6-4: generic standard, transient emissions; industrial sector



Rheinau, den 21.11.2013	Martin Zimmer
(Date and place for issuing)	(legally binding signature) Managing partners

13. Technical data
Series VEE9

	VEE9210	VEE9220		
Installation position	user-defined	user-defined		
Permissible unevenness of mounting surface [mm]	< 0,02	< 0,02		
Mounting separators / tightening torque [Nm]	M3 / 1,5	M3 / 1,5		
	M4 / 2,8	M4 / 2,8		
Replacement accuracy [mm]	< 0,2	< 0,2		
Stroke [mm]	10	20		
Extending/retracting force	10	8		
Number of cycle continuous operation max. [Zyklen/min]	180	180		
Number of cycle maximum. [Zyklus/min]	250	250		
Operating time[ms]	< 20	< 35		
Repeatability ± [mm]	0,1	0,1		
Weight per plunger extension maximum [g]	20	20		
Mounting plunger extension / tightening torqu[Nm]	M3 / 1,5	M3 / 1,5		
Maximum acceptable static force and torque				
Mr [Nm]	0,3	0,3		
Mx [Nm]	0,3	0,3		
My [Nm]	0,3	0,3		
FA [N]	50	50		



Pulse time extended [ms]	35	50		
Pulse time retracted [ms]	35	50		
Debounce time [ms]	10	10		
Current consumption per pulse maximum[A]	5	5		
Current consumption in a stand-by mode [A]	0,02	0,02		
Cable length maximum[m]	10	10		
Protection class	IP40	IP40		
Approval	CE	CE		
Noise level [db(A)]	< 70	< 70		

Service temperature [°C]	10 bis 50
Storage temperature [°C]	-10 bis 50
Maintenance interval [Zyklen]	up to 30 million

Raw material information	
Housing	aluminium, anodized
Plunger	hard-coated Al - alloy, anodized
Screws	steel, corrosion-resistant
Electronics	RoHS - conform

Weight [kg]	0,24	0,30		
-------------	------	------	--	--

