

1. Supporting documents

NOTICE:

Read through the installation and operating instructions carefully before installing the product! The installation and operating instructions contain important notes for your personal safety. They must be read and understood by all persons who work with or handle the product during any phase of the product lifetime.

The documents listed below are available for download on our website (www.zimmer-group.com). Only those documents currently available on the website are valid.

- Catalogs, drawings, CAD data, performance data
- Information on accessories
- Detailed installation and operating instructions
- Technical data sheets
- General Terms and Conditions of Business with specifications for the warranty entitlement

2. Safety notes

CAUTION:

Non-compliance may result in severe injuries!

1. Installation, commissioning, maintenance and repairs may only be performed by qualified specialists in accordance with these installation and operating instructions.
2. The gripper is state-of-the-art. It is fitted to industrial machines and is used to hold workpieces. The following are examples of situations in which the gripper may cause a hazard:
 - It is not properly installed, used or maintained.
 - It is not used for its intended purpose.
 - Local regulations (legislation, ordinances, guidelines), such as the EC Machinery Directive, accident prevention regulations and the installation and operating instructions, are not observed.
3. The gripper may be used only in accordance with its proper use and technical data. Zimmer GmbH shall accept no liability for any damage caused by improper use.
4. Any use other than the intended use requires written approval from Zimmer GmbH.
5. Do not reach into the operational range of the gripper.
6. Make sure that the power cables are disconnected before you install, modify, maintain or repair the gripper.
7. In case of maintenance, modification or attachment work, remove the gripper from the machine and perform the work outside the danger zone.
8. When commissioning or testing, make sure that the gripper cannot be actuated by mistake.
9. Modifications to the gripper, such as adding drilled holes or threads, may be made only with prior approval from Zimmer GmbH.
10. The specified maintenance intervals and compressed air quality specifications are to be observed; also refer to the Maintenance section. When the gripper is used under extreme conditions, the maintenance interval must be adapted depending on the extent of the contamination.
11. When removing grippers that have an integrated spring, work with extra caution because the spring is always under tension.

3. Proper use

NOTICE:

The gripper is to be used only in its original state with its original accessories, without any unauthorized changes and within the scope of its defined parameters of use. Zimmer GmbH shall accept no liability for any damage caused by improper use.

The gripper is designed exclusively for pneumatic operation. The gripper is designated for use in enclosed rooms for temporarily gripping, handling and holding parts. The gripper is not suitable for clamping workpieces during a machining process. Direct contact with perishable goods/food is not permitted.

4. Personnel qualification

Installation, commissioning and maintenance may only be performed by qualified personnel. These personnel must have read and understood the installation and operating instructions in full.

5. Product description

5.1 Forces and torques

INFORMATION:

For information on forces and torques, please visit our website.

Zimmer Customer Service is available to provide you with assistance if you have any further questions.

5.2 Type plate

A type plate is attached to the housing of the gripper. The confirmation number and the article number are indicated on this type plate.

- The confirmation number should be assigned to the project.
- ⇒ Article number: ⑩
- ⇒ Confirmation number: ⑪

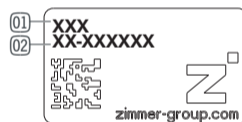

INFORMATION:

Please state the confirmation number in the event of damage or a complaint.

Zimmer Customer Service is available to provide you with assistance if you have any further questions.

6. Function

The function is based on a pneumatic piston vented on both sides. Alternating ventilation causes the pneumatic piston to move up and down. The generated movement is transferred to the gripper jaws by kinematics, thereby producing the gripping force.

Fig. 1: GD300

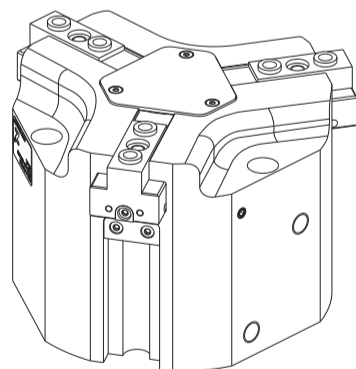

①	Gripper jaw
②	Integrated gripping force safety device
③	Position sensing
④	Power supply
⑤	Positive-drive wedge hook transmission
⑥	Switch cam
⑦	Mounting block
⑧	Housing
⑨	Mounting and positioning

Fig. 2: Cutaway view of the GD300

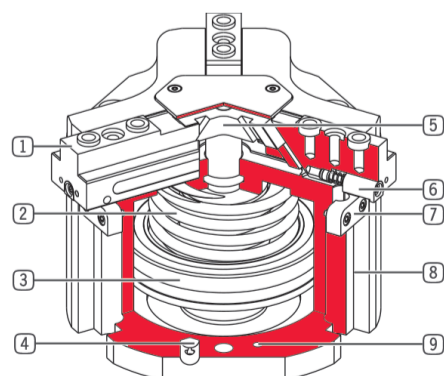

7. Installation

NOTICE:

Switch off the power supply before any assembly, installation or maintenance work.

CAUTION:

Risk of injury in the event of unexpected movement of the gripper when the energy supply is connected.

- Switch off the power supply to the gripper before all work.
- Secure the power supply against being switched on unintentionally.
- Check the power supply for any residual energy.

WARNING:

Risk of injury in case of unexpected movement of the machine or system into which the gripper is to be installed.

- Switch off the power supply to the machine before all work.
- Secure the machine against being switched on unintentionally.
- Check the machine for any residual energy.

7.1 General installation information

The gripper must be installed on a mounting surface in accordance with the specifications for flatness.

Diameter < 100 mm → permitted flatness imperfection < 0.02 mm
 Diameter < 100 mm → permitted flatness imperfection < 0.05 mm

- ⇒ The mounting screws are not included in the scope of delivery.
- ⇒ Strength class of the mounting screws at least 8.8 DIN EN ISO 4762.
- ⇒ Observe the tightening torque of the mounting screws.
- ⇒ Make sure the mounting surface is sufficiently rigid and flat.

7.2 Installing the gripper

The gripper can be installed from multiple sides on the mounting piece. The following work steps must be observed during installation:

- Insert the straight pins ⑪ into the designated fits on the gripper.
- Use the straight pins ⑪ to position the gripper on the designated mounting piece.
- Use suitable mounting screws ⑩ to secure the gripper to the mounting piece.

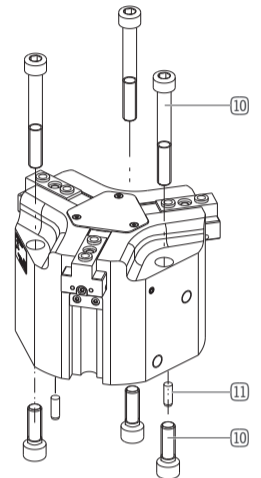

7.3 Installing the power supply

- Insert the screw fittings ⑫ into the designated connections.

Multiple alternative connections are available.

NOTICE:

Close off unused pneumatic connections with dummy plugs. The authorized pneumatic connections that are available can be found in the accessories list, which is available on our website. The necessary ordering information can also be found there.

- ⇒ Use compressed air in accordance with DIN ISO 8573-1 [4:4:4].

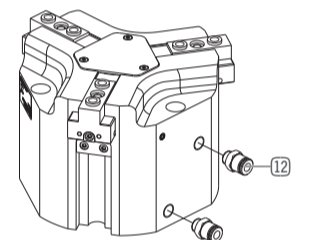

7.4 Installing the gripper fingers

NOTICE:

Before installing the gripper fingers, make sure they have a suitable length for the selected gripper variant.

For more information, refer to our website. Zimmer Customer Service is available to provide you with assistance if you have any further questions.

7.5 Installation of accessories

NOTICE:

Before installing an accessory, make sure it is suitable for use with the selected variant.

For information on all available accessories, please visit our website.

8. Technical data

INFORMATION:

For technical data, please visit our website. This data varies within the series, depending on the specific design.

Zimmer Customer Service is available to provide you with assistance if you have any further questions.

9. Maintenance

Maintenance-free operation of the gripper is guaranteed for up to **10 million cycles**. The maintenance interval may shorten under the following circumstances:

- Operation with compressed air that does not comply with DIN ISO 8573-1 [4:4:4]
- Dirty environment
- Improper use and use that does not comply with the performance data
- Ambient temperature above 60 °C

Even though the gripper is, as mentioned, maintenance-free, carry out a visual inspection on a regular basis to check for any damage or soiling. Dismantling and reassembling the gripper without authorization may result in complications, as special installation equipment is required in some cases. Zimmer GmbH accepts no liability for any resulting malfunction or damage.

10. Declaration of Incorporation

In terms of the EU Machinery Directive 2006/42/EC (Annex II 1 B).

Name and address of the manufacturer:
 Zimmer GmbH • Im Salmenkopf 5 • 77866 Rheinau, Germany • +49 7844 9138 0 • +49 7844 9138 80 • www.zimmer-group.com

We hereby declare that the incomplete machine described below

Product designation: 3-jaw concentric gripper, pneumatic
Type designation: GD3□□ series

satisfies the following basic design requirements of the Machinery Directive 2006/42/EC. The following harmonized standards have been applied:
 No. 1.1.2., No. 1.1.3., No. 1.1.5., No. 1.3.2., No. 1.3.4., No. 1.3.7., No. 1.5.3., No. 1.5.4., No. 1.5.8., No. 1.6.4., No. 1.7.1., No. 1.7.4.

The manufacturer has a full list of the applied standards.

We also declare that the specific technical documents were produced in accordance with Annex VII Part B of this Directive. We undertake to provide the market supervisory bodies with electronic versions of special documents for the incomplete machine through our documentation department, should they have reason to request them. The incomplete machine may only be commissioned if it has been ascertained, if applicable, that the machine or system in which the incomplete machine is to be installed satisfies the requirements of Directive 2006/42/EC on Machinery and an EC Declaration of Conformity has been drawn up in accordance with Annex II 1 A.

Authorized representative for the compilation of relevant technical documents

Kurt Ross	See manufacturer's address	Rheinau, Germany, 2020-04-03	Martin Zimmer, Managing Director
First name, last name	Address	Place and date of issuance	Legally binding signature