



## INSTALLATION AND OPERATING INSTRUCTIONS

Storage station

ALWR1-50-A series

DDOC01075

THE KNOW-HOW FACTORY



**Content**

- 1 Supporting documents ..... 4
  - 1.1 Notices and graphics in the installation and operating instructions .....4
- 2 Safety notices ..... 5
- 3 Proper use ..... 6
- 4 Personnel qualification ..... 6
- 5 Product description ..... 7
  - 5.1 Type plate .....7
- 6 Functional description ..... 7
  - 6.1 First-time setup (end effector with loose part with storage station).....7
  - 6.2 Sensors .....8
    - 6.2.1 Wiring diagram sensor system .....9
    - 6.2.2 Adjust the sensors in the inspection position .....9
    - 6.2.3 Adjust the sensors in the storage position .....9
  - 6.3 Functional safety .....10
- 7 Technical data ..... 10
  - 7.1 Forces and torques.....10
- 8 Accessories/scope of delivery ..... 10
- 9 Transportation/storage/preservation ..... 11
- 10 Installation ..... 12
  - 10.1 Installing the product.....13
  - 10.2 Installing accessories .....13
- 11 Maintenance ..... 14
  - 11.1 Maintaining the sensors .....14
- 12 Decommissioning/disposal ..... 14
- 13 Declaration of Incorporation ..... 15

## 1 Supporting documents

### NOTICE



Read through the installation and operating instructions before installing or working with the product.

The installation and operating instructions contain important notes for your personal safety. They must be read and understood by all persons who work with or handle the product during any phase of the product lifetime.



The documents listed below are available for download on our website [www.zimmer-group.com](http://www.zimmer-group.com).

- Installation and operating instructions
  - Catalogs, drawings, CAD data, performance data
  - Information on accessories
  - Technical data sheets
  - General Terms and Conditions, including warranty information.
- ⇒ Only those documents currently available on the website are valid.

In these installation and operating instructions, "product" refers to the product designation on the title page!

### 1.1 Notices and graphics in the installation and operating instructions

#### DANGER



This notice warns of an imminent danger to the life and health of people. Ignoring these notices can lead to serious injury or even death.

- ▶ You absolutely must comply with the described measures for avoiding these dangers!
- ⇒ The warning symbols are assigned according to the type of danger.

#### WARNING



This notice warns of a situation that is potentially hazardous to personal health. Ignoring these notices can cause serious injury or damage to health.

- ▶ You absolutely must comply with the described measures for avoiding these dangers!
- ⇒ The warning symbols are assigned according to the type of danger.

#### CAUTION



This notice warns of a situation that is potentially hazardous for people or that may result in material or environmental damage. Ignoring these notices may result in slight, temporary injuries or damage to the product or to the environment.

- ▶ You absolutely must comply with the described measures for avoiding these dangers!
- ⇒ The warning symbols are assigned according to the type of danger.

#### NOTICE



General notices contain usage tips and valuable information, but no warnings of dangers to health.

#### INFORMATION



This category contains useful tips for handling the product efficiently. Failure to observe these tips will not result in damage to the product. This information does not include any information relevant to health or workplace safety.

## 2 Safety notices

### CAUTION



#### **Risk of injury and material damage in case of non-compliance**

Installation, commissioning, maintenance and repairs may only be performed by qualified specialists in accordance with these installation and operating instructions.

The product is state-of-the-art.

It is fitted to industrial machines and is used to hold, transport and store workpieces.

The following are examples of situations in which the product may cause a hazard:

- The product is not properly installed, used or maintained.
- The product is not used for its designated purpose.
- The locally applicable regulations, laws, directives or guidelines are not observed.
- ▶ The product may only be used in accordance with these installation and operating instructions and the product's technical data. Any changes or additions to the intended use of the product, as well as modifications to the product, such as those in the following examples, require the written permission of the manufacturer:
  - Use of the product under extreme conditions, such as aggressive fluids or abrasive dusts
  - Additional drilled holes or threads
- ⇒ Zimmer GmbH shall accept no liability for any damage caused by improper use. The operator bears sole responsibility.
- ▶ Make sure that the power supply is disconnected before you mount, adjust, modify, maintain or repair the product.
- ▶ Whenever work is carried out on the product, make sure that the product cannot be actuated by mistake.
- ▶ Perform maintenance tasks, renovation work or attachment work outside of the machine's danger zone when possible.
- ▶ Do not reach into the operational range of the product.
- ▶ Observe the specified maintenance intervals and specifications regarding the quality of the operating material.
- ▶ When using the product under extreme conditions, adjust the maintenance interval according to the degree of contamination.

### 3 Proper use

#### NOTICE



The product is only to be used in its original state with its original accessories, with no unauthorized changes and within the stipulated parameter limits and operating conditions.

Any other or secondary use is deemed improper.

- ▶ Operate the product only in compliance with the associated installation and operating instructions.
- ▶ Operate the product only when it is in a technical condition that corresponds to the guaranteed parameters and operating conditions.
- ⇒ Zimmer GmbH shall accept no liability for any damage caused by improper use. The operator bears sole responsibility.

---

The product is designed exclusively for depositing end effectors with loose part with or without tools.

The product may be loaded with a maximum of 5 kg.

The product is designated for use in closed facilities.

Direct contact with perishable goods/food is not permitted.

### 4 Personnel qualification

Installation, commissioning and maintenance may only be performed by trained specialists. These persons must have read and understood the installation and operating instructions in full.

## 5 Product description

### 5.1 Type plate

A type plate is attached to the housing of the product.

The article number and confirmation number are shown on the type plate.

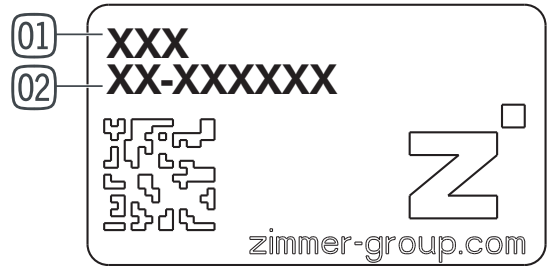

- ① Article number
- ② Confirmation number

## 6 Functional description

The storage station is a device in which a completely equipped end effector with loose part can be held ready in a defined position.

Several storage stations can be used to hold differently equipped end effectors with loose part for operation with a stationary part.

The end effectors with loose part and storage station are developed to rule out any incorrect insertion of the end effector with loose part into the storage station.

- ① Storage station
- ② Mounting and positioning
- ③ Sensor in storage position (end effector with loose part present)
- ④ Sensor in inspection position (locking extended)
- ⑤ Limit stop

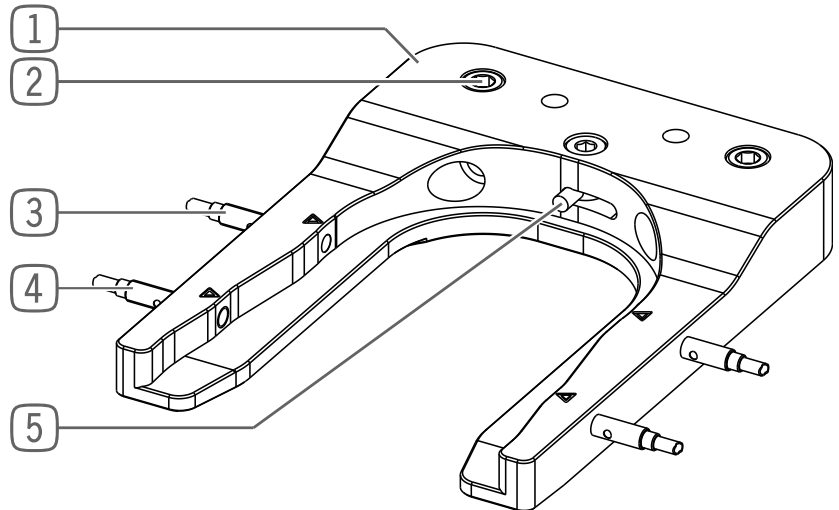

### 6.1 First-time setup (end effector with loose part with storage station)

- ▶ When setting up an end effector with loose part in the storage station for the first time, rotate the pin of the limit stop out of the storage station.
  - ▶ Teach in your robot to the position needed.
  - ▶ After successful teach-in, turn the pin of the limit stop back into the storage station pivoted by 90°.
- ⇒ This creates a floating bearing for the end effector with loose part.

## 6.2 Sensors

Example image of a combination consisting of a stationary part, end effector with loose part, and storage station.

Check up to two sensors in the storage position to see whether the end effector with loose part is present in the storage station.

Then move the stationary part onto the end effector with loose part from above. The centering pins of the end effector with loose part help in insertion.

The robot, along with the stationary part and end effector with loose part, moves to the inspection position sensors in the storage station.

The two sensors in the inspection position (test channel) respond if the lockings are extended and make contact in the stationary part.

When the stationary part and end effector with loose part are joined, the internal spring-pin contacts for signal transmission are contacted.

Then the Connect LED changes color from red to green and a Connect signal (depending on the variant) is passed to the higher-level control system.

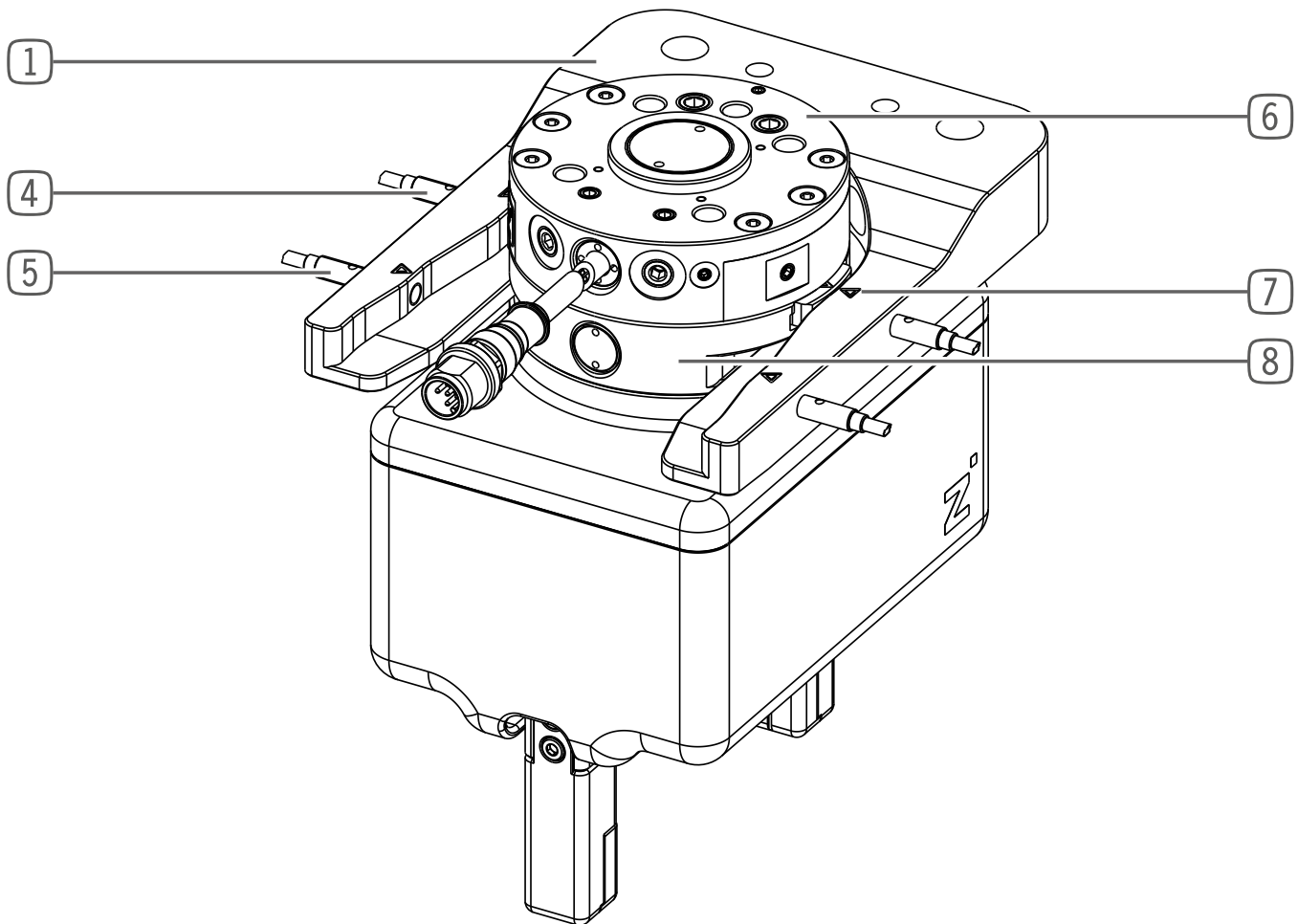

- |   |  |
|---|--|
| ① Storage station   | ⑥ Fixed part for quick-change system                   |
| ④ Sensor in storage position (end effector with loose part present) | ⑦ Locking  |
| ⑤ Sensor in inspection position (test channel, locking extended)    | ⑧ End effector with loose part for quick-change system |



**6.2.1 Wiring diagram sensor system**

Sensor plug connection M8 3-pin:

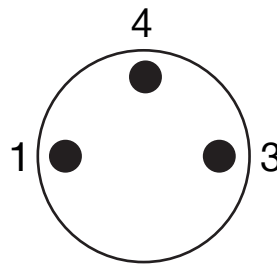

Graphical symbol for sensor in storage position

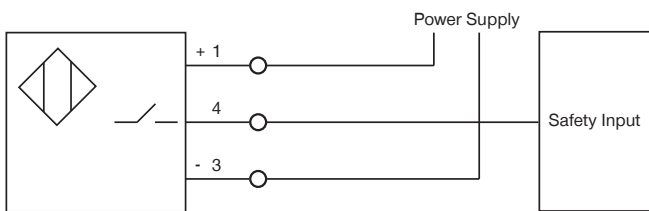

2 sensors in inspection position connected in series

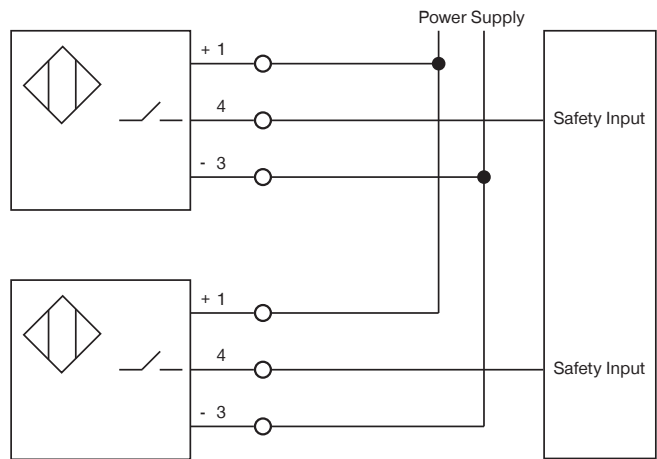

**6.2.2 Adjust the sensors in the inspection position**

- ▶ Bring the markings on the locking elements of the end effector with loose part to the position of the front markings of the storage station.
- ▶ Turn in the sensors until they emit a signal.
- ▶ Fasten the sensors at this position.
- ▶ Coat the sensors with sealing lacquer.

**6.2.3 Adjust the sensors in the storage position**

- ▶ Position an end effector with loose part in the storage station.
- ▶ Turn in the sensors until they emit a signal.
- ▶ Coat the sensors with sealing lacquer.

- ⑨ Sensor in storage position (end effector with loose part present)
- ⑩ Sensor in inspection position (test channel, locking extended)

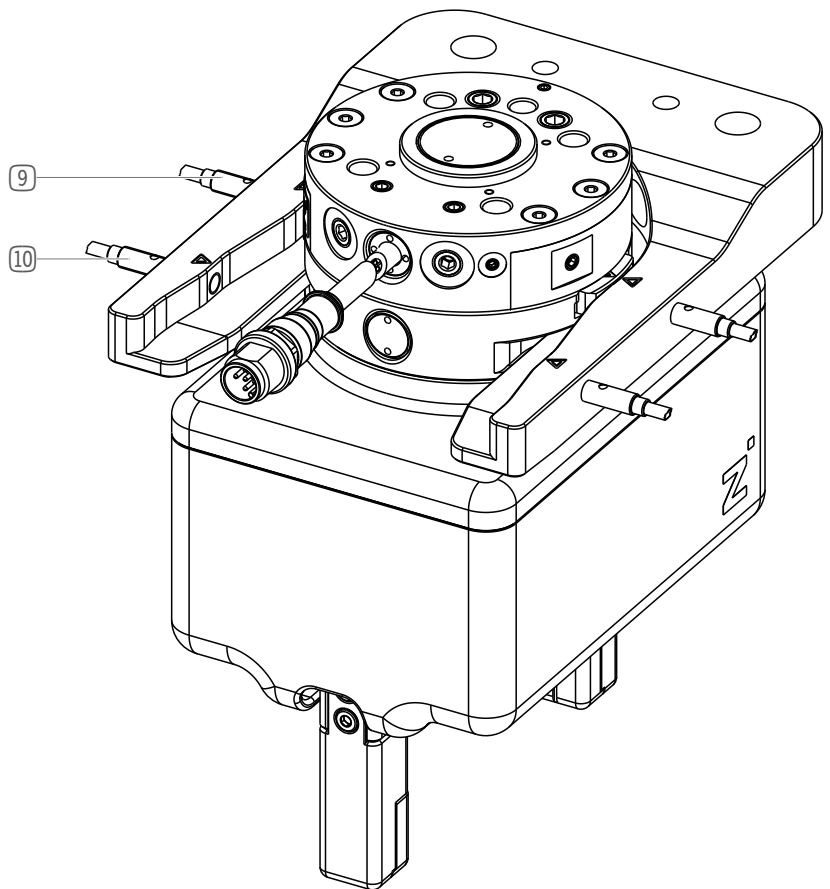

### 6.3 Functional safety

For the overall safety of the function, all three components (stationary part, end effector with loose part and storage station) must be taken into account.

The safety function that ensures secure locking between the stationary part and end effector with loose part of the product is implemented via two redundant action channels that consist of a mechanical locking and springs.

Technical supplementary safety measures (sensors) provide a high degree of diagnostic coverage. The product can thus be classified into control category 3 in accordance with Chapter 6.2.6 of DIN EN ISO 13849-1. According to Figure 5, Chapter 4.5.4 of the specified standard, the PL d can be achieved with this product.

Fault elimination in accordance with DIN EN ISO 13849-2, Annex A, Table A2 and A3 for the helical compression springs used can be given.

## 7 Technical data

### INFORMATION



- ▶ For technical data, refer to our website.
- This data varies within the series, depending on the specific design.
- ▶ Please contact Zimmer Customer Service if you have any questions.

### 7.1 Forces and torques

### INFORMATION



- ▶ You can find information on our website.
- ▶ Please contact Zimmer Customer Service if you have any questions.

### NOTICE



- Non-compliance may result in material damage.**
- ▶ Align the end effector with loose part parallel to the storage station and, in terms of height and twisting, such that it can be guided into the storage station with the least amount of force possible.
  - ▶ Comply with the specified forces.

Force [N]	Action
approx. 40	Guide the end effector with loose part into the storage station.
approx. 20	Remove the end effector with loose part from the storage station.

## 8 Accessories/scope of delivery

### INFORMATION



- If any accessories not sold or authorized by Zimmer GmbH are used, the function of the product cannot be guaranteed. Zimmer GmbH accessories are specifically tailored to the individual products.
- ▶ For optional accessories and those included in the scope of delivery, refer to our website.

## 9 Transportation/storage/preservation

- ▶ Transport and storage of the product must be done only with the original packaging.
- ▶ If the product has already been installed on the superordinate machine unit, care must be taken during transport to ensure that no unexpected movements can occur.
  - ▶ Before commissioning the product and after transport, check all power and communication connections as well as all mechanical connections.
- ▶ If the product is stored for an extended period, the following points are to be observed:
  - ▶ Keep the storage location as dust-free and dry as possible.
  - ▶ Avoid temperature fluctuations/observe and adhere to the temperature range.
  - ▶ Avoid wind/drafts/water condensation formation.
  - ▶ Cover the product with a weatherproof, tear-resistant foil to prevent dust.
  - ▶ Pack the product and do not expose it to direct sunlight during storage.
- ▶ Clean all components. There must be no soiling left on the components.
- ▶ Visually inspect all components.
- ▶ Remove all foreign substances.
- ▶ Properly remove potential corrosion spots.

## 10 Installation

### WARNING



#### Risk of injury due to uncontrolled movements

Risk of injury in case of unexpected movement of the machine or system into which the product is to be installed.

- ▶ Switch off the energy supply of the machine before any work.
- ▶ Secure the power supply against being switched on unintentionally.
- ▶ Check the machine for any residual energy that may be present.

### NOTICE



▶ Installation may only be carried out by qualified personnel in accordance with these installation and operating instructions.

▶ Switch off the power supply before any assembly, installation or maintenance work.

▶ Install the product on an appropriate mounting surface in accordance with the flatness specifications.

### INFORMATION



Requirements for the mounting surface:

- Permissible unevenness: 0.03 mm

Further installation information:

- The mounting screws are not included in the scope of delivery.
- Strength class of the mounting screws is at least 8.8 (DIN EN ISO 4762)

▶ Observe the tightening torque of the mounting screws.

▶ Verify the permitted load capacity of the required screw connections in accordance with VDI 2230.

### 10.1 Installing the product

The product can be mounted to the mounting piece using the installation holes.

The product can be installed from multiple sides.

- ▶ Insert straight pins into the fits of the storage station.
- ▶ Position the storage station on the mounting piece.
- ▶ Fasten the storage station using the mounting screws.
- ▶ Observe the tightening torque of the mounting screws.

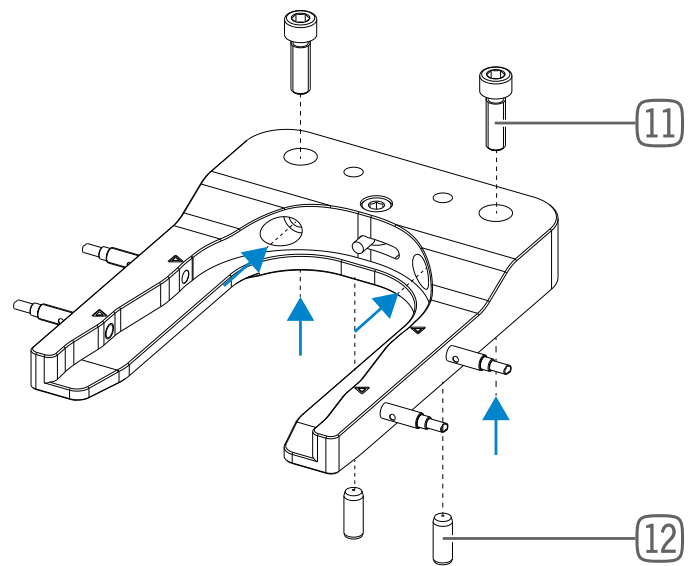

⑪ Mounting screw

⑫ Straight pins

### 10.2 Installing accessories

#### NOTICE



Before installing an accessory, make sure it is suitable for use with the selected variant.

- ▶ You can find information on our website.

## 11 Maintenance

Operation of the product is maintenance-free.

- ▶ Even though the product is maintenance-free as mentioned above, perform a regular visual inspection to check for any corrosion, damage or contamination.
- ▶ Have maintenance work be performed by Zimmer Customer Service whenever possible.
- ⇒ Dismantling and reassembling the product without authorization may result in complications, as special installation equipment is required in some cases. Zimmer GmbH accepts no liability for any resulting malfunctions or damage.
- ⇒ Zimmer GmbH shall accept no liability for any damage caused by improper use. The operator bears sole responsibility.

### 11.1 Maintaining the sensors

- ▶ Observe the manufacturer information when maintaining or cleaning the sensors.
- ▶ Check the sensors at regular intervals for possible damage and contamination.

## 12 Decommissioning/disposal

### INFORMATION



When the product reaches the end of its operational phase, it can be completely disassembled and disposed of.

- ▶ Disconnect the product completely from the power supply.
  - ▶ Dispose of the components properly according to the material groups.
  - ▶ Comply with the locally applicable environmental and disposal regulations.
-

### 13 Declaration of Incorporation

In terms of the EU Machinery Directive 2006/42/EC (Annex II 1 B)

**Name and address of the manufacturer:**

**Zimmer GmbH**

- 📍 Im Salmenkopf  
77866 Rheinau, Germany
- ☎ +49 7844 9138 0
- ✉ [info@zimmer-group.com](mailto:info@zimmer-group.com)
- 🌐 [www.zimmer-group.com](http://www.zimmer-group.com)

We hereby declare that the incomplete machine described below

- Product designation:** Storage station
- Type designation:** ALWR1-50-A series

conform to the requirements of the Machinery Directive, 2006/42/EC, Article 2g, Annex VII.b – Annex II.b, in its design and the version we put on the market.

Basic health and safety requirements:

Nr.1.1.2, Nr.1.1.3, Nr.1.1.5, Nr.1.3.2, Nr.1.3.4, Nr.1.3.7, Nr.1.5.3, Nr.1.5.4, Nr.1.5.8, Nr.1.6.4, Nr.1.7.1, Nr.1.7.4

A full list of applied standards can be obtained from the manufacturer.

We also declare that the specific technical documents were produced in accordance with Annex VII Part B of this Directive. We undertake to provide the market supervisory bodies with electronic versions of special documents for the incomplete machine through our documentation department, should they have reason to request them.

**The incomplete machine may only be commissioned if it has been ascertained, if applicable, that the machine or system in which the incomplete machine is to be installed satisfies the requirements of Directive 2006/42/EC on Machinery and an EC Declaration of Conformity has been drawn up in accordance with Annex II 1 A.**

Kurt Ross	Rheinau, Germany, 2021-04-01	
Authorized representative for the compilation of relevant technical documents	(Place and date of issuance)	Martin Zimmer (Legally binding signature) Managing Partner