

INSTALLATION AND OPERATING INSTRUCTIONS

Energy elements
WER3000

DDOC00214

THE KNOW-HOW FACTORY

Content

1	Introduction	3
1.1	Supporting documents	3
1.2	Notices and graphics in the instructions	3
2	Safety notices	4
3	Proper use	5
4	Personnel qualification	5
4.1	Electricians	5
4.2	Specialists	5
4.3	Instructed personnel.....	5
4.4	Service personnel.....	5
4.5	Additional qualifications	5
5	Product description	6
5.1	Type plate	7
5.2	Product variants	7
6	Functional description	7
7	Technical data	8
8	Accessories/scope of delivery	8
9	Transportation/storage/preservation	8
10	Installation	9
10.1	Aligning the plug.....	10
10.2	Installing the product on WPR5000	12
10.2.1	Installing non-contact energy elements.....	13
10.2.2	Installing hydraulic energy elements.....	14
10.3	Installing the product on WWR.....	15
10.3.1	Installing non-contact energy elements.....	17
10.3.2	Installing hydraulic energy elements.....	19
10.4	Installing the energy supply	22
10.4.1	Electrical products.....	22
10.4.2	Hydraulic products	22
10.4.3	Pneumatic products	22
10.5	Encoding the energy elements.....	23
10.6	Installing the protective elements.....	24
10.7	Installing the sensors.....	25
11	Maintenance.....	26
12	Decommissioning/disposal	27
13	RoHS declaration.....	28
14	Declaration of Incorporation (Machinery Directive)	29
15	Declaration of Incorporation	30
16	Declaration of Conformity	31

1 Introduction

1.1 Supporting documents

NOTICE



Read through the instructions before installing or working with the product.

The instructions contain important notes for your personal safety. They must be read and understood by all persons who work with or handle the product during any phase of the product lifetime.



The documents listed below are available for download on our website www.zimmer-group.com.

- Instructions
 - Catalogs, drawings, CAD data, performance data
 - Information on accessories
 - Technical data sheets
 - General Terms and Conditions, including warranty information.
- ⇒ Only those documents currently available on the website are valid.

In these instructions, "product" refers to the product designation on the title page!

1.2 Notices and graphics in the instructions

DANGER



This notice warns of an imminent danger to the life and health of people. Ignoring these notices can lead to serious injury or even death.

- ▶ You absolutely must comply with the described measures for avoiding these dangers!
- ⇒ The warning symbols are assigned according to the type of danger.

WARNING



This notice warns of a situation that is potentially hazardous to personal health. Ignoring these notices can cause serious injury or damage to health.

- ▶ You absolutely must comply with the described measures for avoiding these dangers!
- ⇒ The warning symbols are assigned according to the type of danger.

CAUTION



This notice warns of a situation that is potentially hazardous to persons. Ignoring these notices can cause minor, reversible injuries.

- ▶ You absolutely must comply with the described measures for avoiding these dangers!
- ⇒ The warning symbols are assigned according to the type of danger.

NOTICE



This notice warns of possible material and environmental damage. Ignoring these notices can result in damage to the product or the environment.

- ▶ You absolutely must comply with the described measures for avoiding these dangers!
- ⇒ The warning symbols are assigned according to the type of danger.

INFORMATION



This category contains useful tips for handling the product efficiently. Failure to observe these tips will not result in damage to the product. This information does not include any information relevant to health or workplace safety.

2 Safety notices

CAUTION



Risk of injury and material damage in case of non-compliance

The product is state-of-the-art.

The following are examples of situations in which the product may cause a hazard:

- The product is not properly installed, used or maintained.
- The product is not used for its designated purpose.
- The locally applicable regulations, laws, directives or guidelines are not observed.
- ▶ The product may only be used in accordance with these instructions and the product's technical data. Any changes or additions to the intended use of the product, as well as modifications to the product, such as those in the following examples, require the written permission of the manufacturer:
 - Use of the product under extreme conditions, such as aggressive fluids or abrasive dusts
 - Additional drilled holes or threads
- ⇒ Zimmer Group GmbH shall accept no liability for any damage caused by improper use. The operator bears sole responsibility.
- ▶ Make sure that the power supply is disconnected before you mount, adjust, modify, maintain or repair the product.
- ▶ Whenever work is carried out on the product, make sure that the product cannot be actuated by mistake.
- ▶ Perform maintenance tasks, renovation work or attachment work outside of the machine's danger zone when possible.
- ▶ Do not reach into the operational range of the product.
- ▶ Always adhere to the required maintenance intervals.
- ▶ When using the product under extreme conditions, adjust the maintenance interval according to the degree of contamination.
- ▶ Check the completeness and tightening torques of all mounting screws.

3 Proper use

NOTICE



Material damage and malfunction in case of non-compliance

The product is only to be used in its original state with its original accessories, with no unauthorized changes and within the stipulated parameter limits and operating conditions.

Any other or secondary use is deemed improper.

- ▶ Operate the product only in compliance with the associated instructions.
 - ▶ Operate the product only when it is in a technical condition that corresponds to the guaranteed parameters and operating conditions.
- ⇒ Zimmer Group GmbH shall accept no liability for any damage caused by improper use. The operator bears sole responsibility.

- The product is designated for use in closed facilities.
- The product is intended for industrial use.
- The product is not suited for use in a potentially explosive atmosphere.
- The product is mounted on the tool changer and is used for media transfer.

4 Personnel qualification

WARNING



Inadequate qualification can cause injury and material damage

If inadequately qualified personnel perform work on the product, this can cause serious injuries and significant material damage.

- ▶ All work on the product must be performed by qualified personnel.
- ▶ Before working with the product, read the document in its entirety and make sure that you have understood everything.
- ▶ Observe country-specific accident prevention regulations and the general safety notices.

The following qualifications are a prerequisite for performing various work on the product.

4.1 Electricians

Electricians are able to perform work on electrical systems, can recognize and avoid possible dangers and know the relevant standards and provisions due to their technical training, knowledge and experience.

4.2 Specialists

Specialists are able to perform the assigned work, can recognize and avoid possible dangers and know the relevant standards and provisions due to their technical training, knowledge and experience.

4.3 Instructed personnel

Instructed personnel have been trained by the operating company on the tasks and possible dangers of improper behavior.

4.4 Service personnel

Service personnel are able to perform the assigned work and can recognize and avoid possible dangers due to their technical training, knowledge and experience.

4.5 Additional qualifications

Persons who work with the product must be familiar with the valid safety regulations and laws as well as the standards, guidelines and laws listed in this document.

Personnel who work with the product must have facility-issued authorization to commission, program, configure, operate, maintain and also decommission this product.

5 Product description

INFORMATION



- ▶ You can find information about suitable installation sizes of tool changers in the technical data sheet on our website.
- ▶ Please contact Customer Service if you have any questions.

The stationary part of the product is always on the robot side. The loose part is always on the tool side.

The stationary part and loose part can be differentiated by the identifier on the type plate:

- Stationary part: WERxxxxF
- Loose part: WERxxxxL

Example: WPR5000 with WER3000

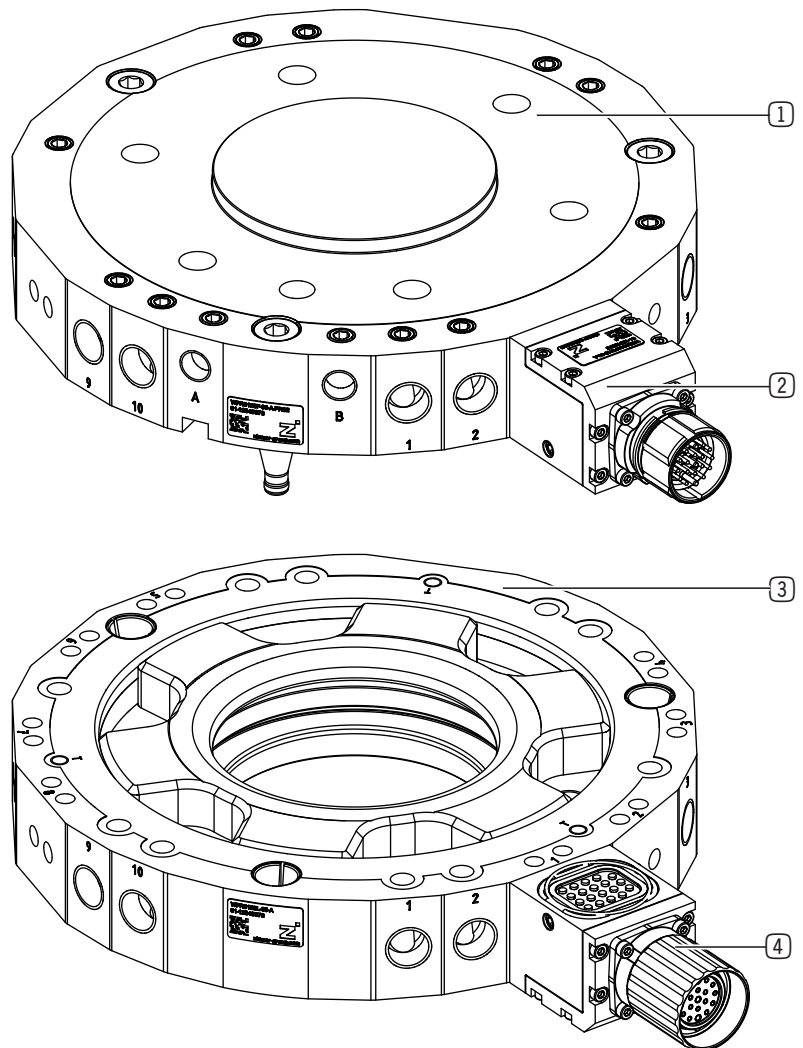

- ① Stationary part of the tool changer
- ② Stationary part of the energy element
- ③ Loose part of the tool changer
- ④ Loose part of the energy element

5.1 Type plate

A type plate is attached to the product.

- ① Article number
- ② Confirmation number

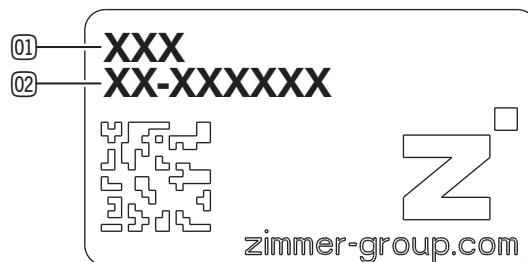

5.2 Product variants

INFORMATION



- ▶ You can find information about product variants and their compatibility on our website.
- ▶ Please contact Customer Service if you have any questions.

6 Functional description

The products transfer media from the robot to the tool.

Depending on the product variant, they are suitable for the transfer of fluids and electrical energy.

7 Technical data

INFORMATION



- ▶ You can find the information in the technical data sheet or Configurator on our website.
- ▶ This data varies within the series, depending on the specific design.

8 Accessories/scope of delivery

INFORMATION



- ▶ If any accessories not sold or authorized by Zimmer Group GmbH are used, the function of the product cannot be guaranteed. Zimmer Group GmbH accessories are specifically tailored to the individual products.
- ▶ For optional accessories and those included in the scope of delivery, refer to our website.

9 Transportation/storage/preservation

- ▶ Transport and storage of the product must be done only with the original packaging.
- ▶ If the product has already been installed on the superordinate machine unit, care must be taken during transport to ensure that no unexpected movements can occur.
 - ▶ Before commissioning the product and after transport, check all power and communication connections as well as all mechanical connections.
- ▶ If the product is stored for an extended period, the following points are to be observed:
 - ▶ Keep the storage location as dust-free and dry as possible.
 - ▶ Avoid temperature fluctuations.
 - ▶ Avoid wind/drafts/water condensation formation.
 - ▶ Pack the product and do not expose it to direct sunlight during storage.
- ▶ Clean all components. There must be no soiling left on the components.
- ▶ Visually inspect all components.
- ▶ Remove all foreign substances.
- ▶ Properly remove potential corrosion spots.
- ▶ Close electrical connections using suitable covers.

10 Installation

DANGER



Potentially life-threatening hazard due to electrical voltage

For electrical products, there is a risk of injury due to exposed contacts that are live at all times.

- ▶ Never mount the loose part of electrical products on the stationary part of a tool changer.
- ▶ Shut off the electrical energy supply before decoupling and in the decoupled state.
- ▶ Make sure that the power supply is disconnected before you mount, modify, maintain or repair the product.

WARNING



Risk of injury due to uncontrolled movements

Risk of injury in case of unexpected movement of the machine or system into which the product is to be installed.

- ▶ Switch off the energy supply of the machine before any work.
- ▶ Secure the power supply against being switched on unintentionally.
- ▶ Check the machine for any residual energy that may be present.

WARNING



Risk of injury from crushing

There is a risk of crushing injuries during coupling.

- ▶ Always keep an adequate safety distance.

NOTICE



Malfunction in case of non-compliance

- ▶ Shut off the electrical energy supply before decoupling and in the decoupled state.
- ▶ Note the technical data sheet for pneumatic products.

10.1 Aligning the plug

The plug orientation of the product is aligned radially in factory condition.

- ▶ Unscrew all mounting screws on the bracket.
- ▶ Store all mounting screws carefully.

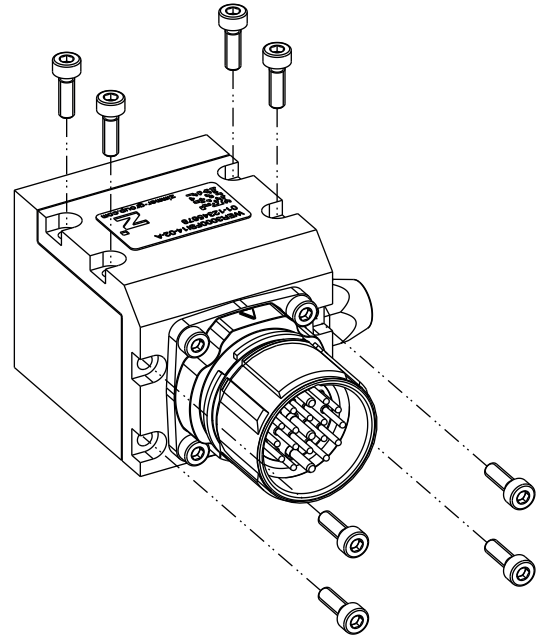

- ▶ Carefully detach the bracket from the housing.
- ▶ During the subsequent work steps, make sure the internal cables do not get damaged.

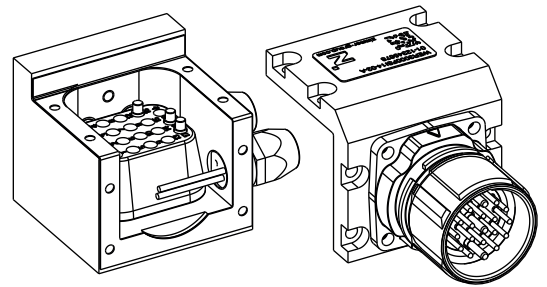

- ▶ Turn the bracket so that the plug orientation is aligned axially.
- ▶ Bring the bracket and the housing back together in this position.

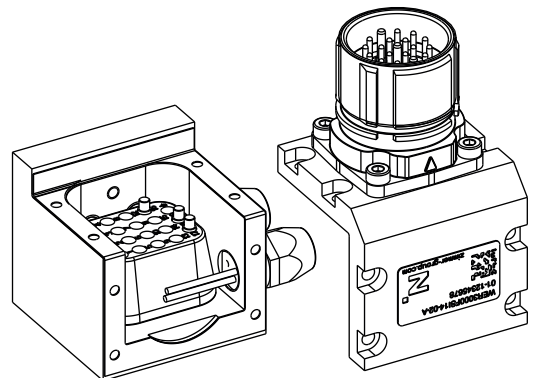

- ▶ Install the bracket on the housing using the mounting screws.
- ▶ Tighten the mounting screws A without distortion.
 - ▶ Comply with the tightening torque of 0.6 Nm.
- ▶ Tighten the mounting screws B without distortion.
 - ▶ Comply with the tightening torque of 0.6 Nm.

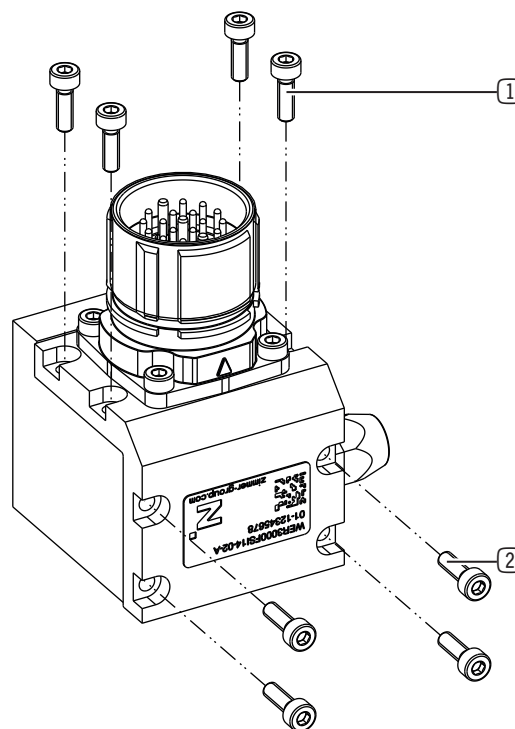

- ① Mounting screw B
- ② Mounting screw A

10.2 Installing the product on WPR5000

INFORMATION



- ▶ If necessary, install the energy supply for electrical products before installing the product on the tool changer.

The products can be connected directly to tool changers of the WPR5000 series.

- ▶ Install the product via the pins.
- ▶ Use grub screws to secure the product.

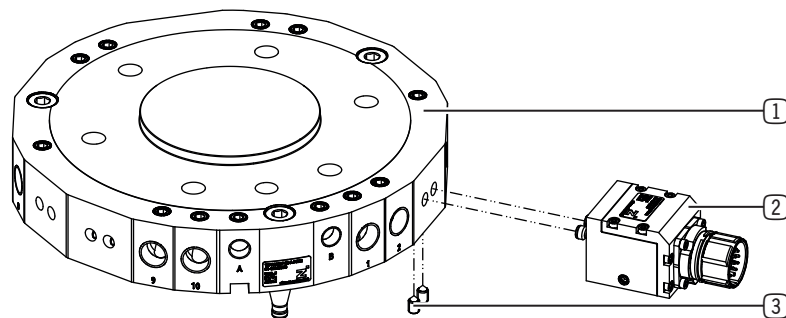

- ① Stationary part of the tool changer
- ② Loose part of the tool changer
- ③ Grub screw
- ④ Stationary part of the energy element
- ⑤ Loose part of the energy element

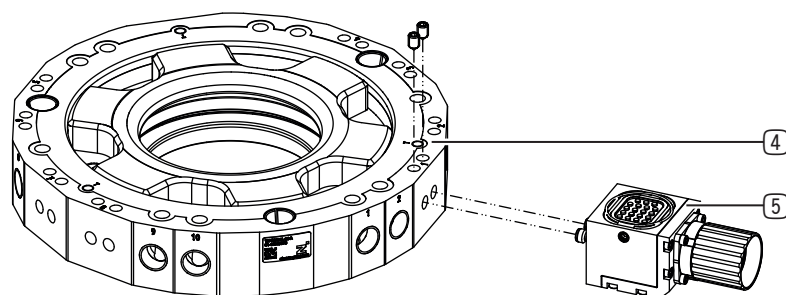

10.2.1 Installing non-contact energy elements

INFORMATION



► Please note that you must replace the exterior pin for the installation of specific product variants depending on the position (left/right).

This concerns the following product variants:

- WER3000FSI08-18-A
- WER3000LSI08-18-A
- WER3000FIL01-18-A
- WER3000LIL01-18-A

► More information about the products can be found on the manufacturer's website.

- www.balluff.com

Zimmer Group GmbH part number	Manufacturer part number
WER3000FSI08-18-A	BIC007J
WER3000LSI08-18-A	BIC007K
WER3000FIL01-18-A	BIC007F
WER3000LIL01-18-A	BIC007H

The illustration shows an example of the positioning of the pins.

► Please note that if non-contact products are used for the WPR5000 series, then no additional products can be installed.

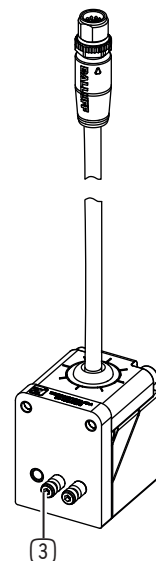
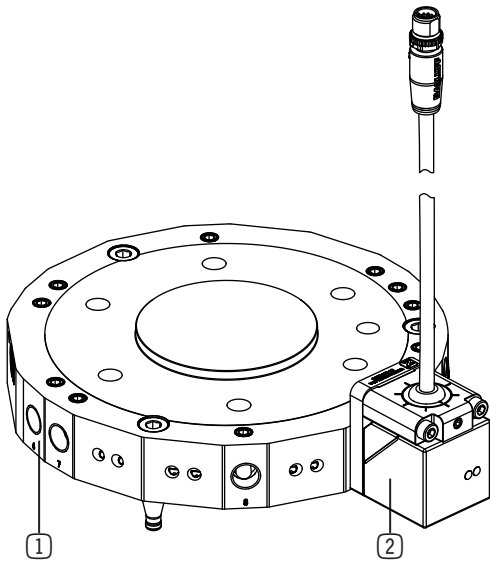

- ① WPR5125F-00-A
- ② WER3000FSI08-18-A
- ③ Pin

10.2.2 Installing hydraulic energy elements

INFORMATION



This chapter pertains to the products WER3000FFL01-03-A and WER3000LFL01-03-A.

WARNING



Risk of injury in case of non-compliance

At operating pressures of 30 bar and higher, high forces are exerted that require the fluidic products to have an additional support or be locked.

- Support on the robot and tool.
 - Pneumatic locking
- ⇒ Without appropriate measures, leaks may result.

► Make sure that hydraulic products are completely covered in their width and at least 70% towards the outside.

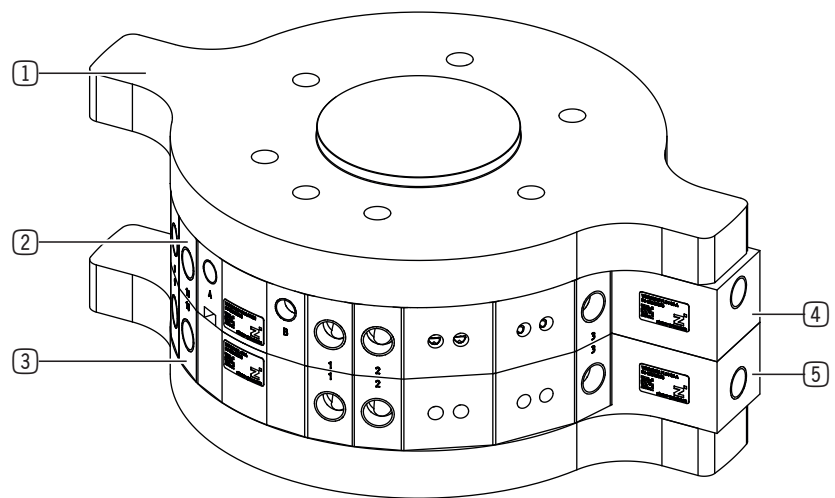

- ① Bracing
- ② Stationary part of the tool changer
- ③ Loose part of the tool changer
- ④ Stationary part of the energy element
- ⑤ Loose part of the energy element

10.2.2.1 Determining the bracing thickness

INFORMATION



► Make sure that the thickness of the bracing meets the minimum requirement shown in the following.

Pressure [bar]	Bracing thickness [mm]	
	Steel	Aluminum
30	3	4
50	5	7
100	6	8
150	7	10

10.3 Installing the product on WWR

INFORMATION



- ▶ If necessary, install the energy supply for electrical products before installing the product on the tool changer.

Adapter plates are required when installing on products of the WWR series.

The following illustration shows an example of product installation on the WWR125 tool changer.

- ▶ Position the adapter plate on the tool changer with the straight pins.
- ▶ Comply with the maximum tightening torque of 1.5 Nm.
- ▶ Mount the adapter plate on the tool changer by using the included mounting screws.
- ▶ Install the energy element with the pins.
- ▶ Use grub screws to secure the product.

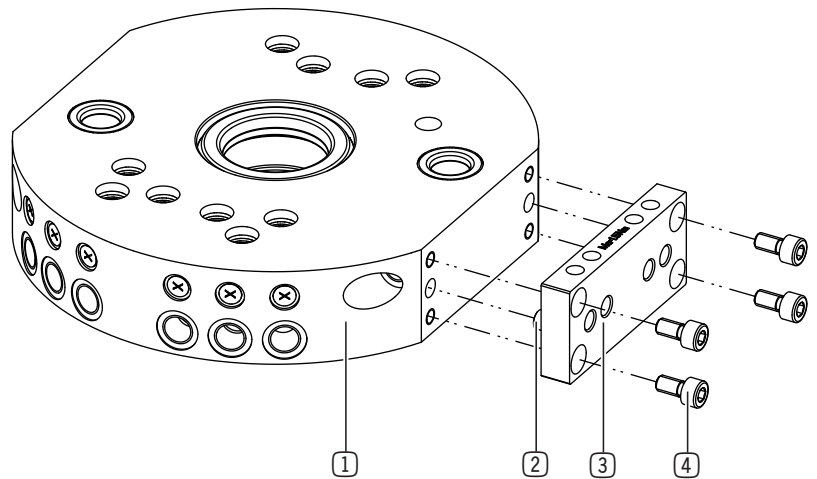

- ① Loose part of the tool changer
- ② Straight pins
- ③ Adapter plate
- ④ Mounting screw
- ⑤ Grub screw
- ⑥ Loose part of the energy element

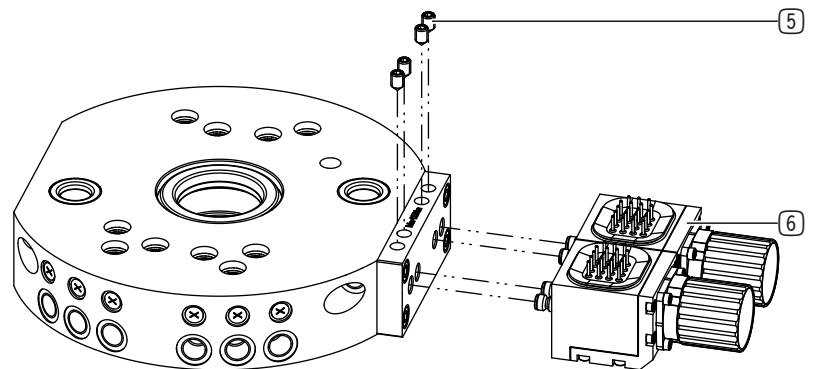

The following illustration shows an example of product installation to the WWR1160 tool changer.

- ▶ Insert the selected adapter plate into the guide on the tool changer.
 - ▶ Comply with the maximum tightening torque of 1.5 Nm.
- ▶ Mount the adapter plate on the tool changer by using the included mounting screws.
- ▶ Install the energy element with the pins.
- ▶ Use grub screws to secure the product.

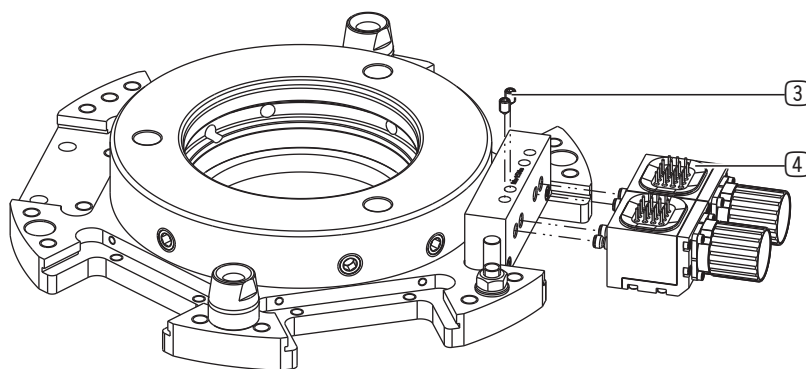
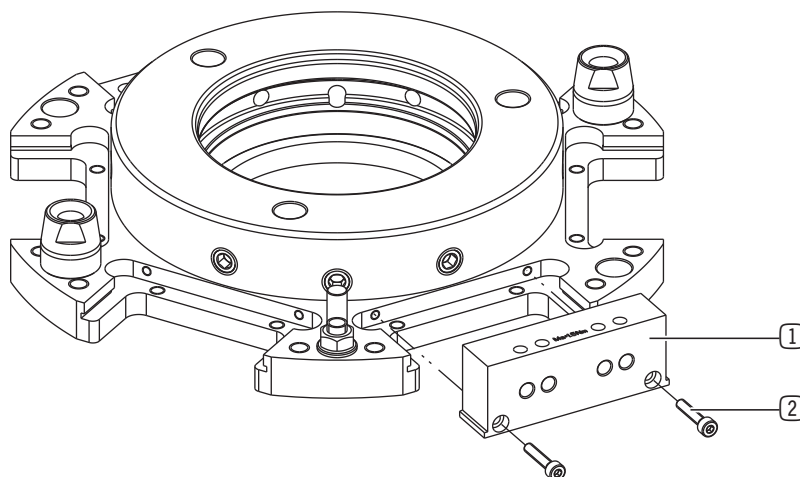

- ① Adapter plate
- ② Mounting screw
- ③ Grub screw
- ④ Loose part of the energy element

10.3.1 Installing non-contact energy elements

INFORMATION



► Please note that you must replace the exterior pin for the installation of specific product variants depending on the position (left/right).

This concerns the following product variants:

- WER3000FSI08-18-A
- WER3000LSI08-18-A
- WER3000FIL01-18-A
- WER3000LIL01-18-A

► More information about the products can be found on the manufacturer's website.

- www.balluff.com

Zimmer Group GmbH part number	Manufacturer part number
WER3000FSI08-18-A	BIC007J
WER3000LSI08-18-A	BIC007K
WER3000FIL01-18-A	BIC007F
WER3000LIL01-18-A	BIC007H

The figure provides an example of the positioning of pins when only one product is installed.

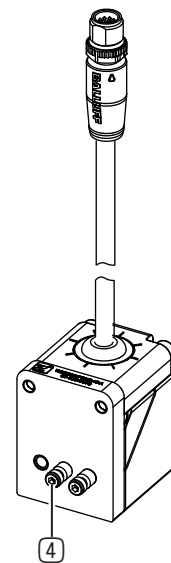
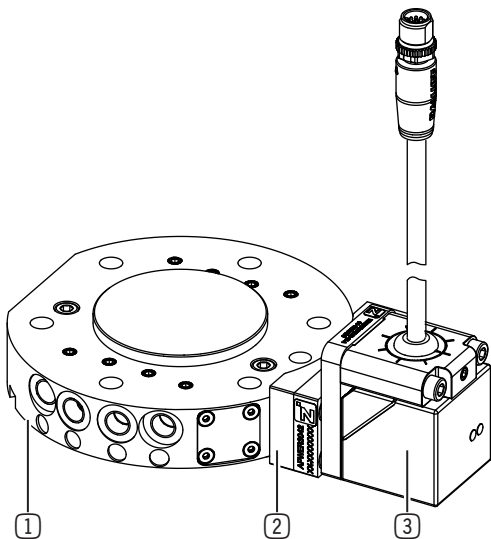

- ① WWR100F
- ② Adapter plate
- ③ WER3000FSI08-18-A
- ④ Pin

The figure provides an example of the positioning of pins when two products are installed.

► Make sure that no pins are positioned at the exterior borehole on the product.

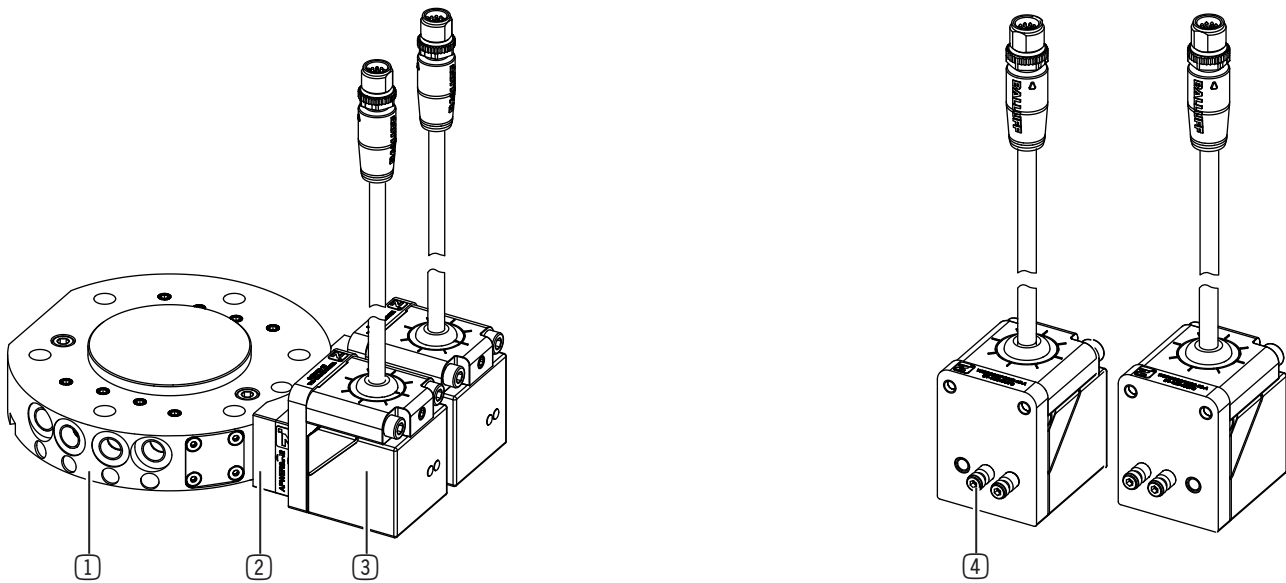

- ① WWR100F
- ② Adapter plate
- ③ WER3000FSI08-18-A
- ④ Pin

10.3.2 Installing hydraulic energy elements

INFORMATION



This chapter pertains to the products WER3000FFL01-03-A and WER3000LFL01-03-A.

WARNING



Risk of injury in case of non-compliance

At operating pressures of 30 bar and higher, high forces are exerted that require the fluidic products to have an additional support or be locked.

- Support on the robot and tool.
 - Pneumatic locking
- ⇒ Without appropriate measures, leaks may result.

► Make sure that hydraulic products are completely covered in their width and at least 70% towards the outside.

- ① Bracing
- ② Stationary part of the tool changer
- ③ Loose part of the tool changer
- ④ Robot
- ⑤ Stationary part of the energy element
- ⑥ Loose part of the energy element
- ⑦ Adapter plate

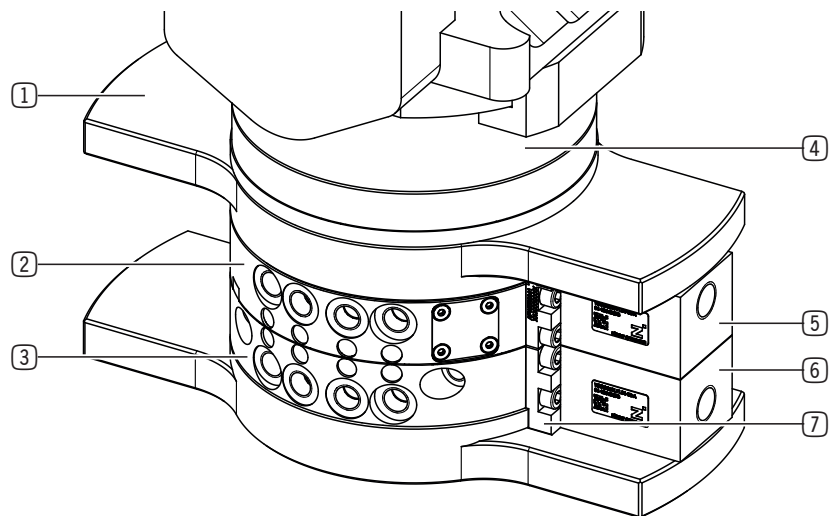

INFORMATION



► Make sure that the thickness of the bracing meets the minimum requirement shown in the following tables.

10.3.2.1 Determining the bracing thickness for the WWR125 installation size

Adapter plates: APWER3041, APWER3042			
Number of products	Pressure [bar]	Bracing thickness [mm]	
		Steel	Aluminum
1	30	2	3
1	50	3	5
1	100	4	6
1	150	5	7
2	30	2	4
2	50	3	5
2	100	4	7
2	150	5	8

10.3.2.2 Determining the bracing thickness for the WWR125 installation size

Adapter plates: APWER3041, APWER3042			
Number of products	Pressure [bar]	Bracing thickness [mm]	
		Steel	Aluminum
1	30	3	4
1	50	4	6
1	100	5	7
1	150	6	8
2	30	3	4
2	50	4	6
2	100	5	7
2	150	6	9
3	30	3	4
3	50	5	7
3	100	6	8
3	150	7	10
4	30	4	5
4	50	5	7
4	100	6	9
4	150	8	11

10.3.2.3 Determining the bracing thickness for the WWR160 installation size

Adapter plates: APWER3041, APWER3042			
Number of products	Pressure [bar]	Bracing thickness [mm]	
		Steel	Aluminum
1	30	3	4
1	50	5	7
1	100	6	8
1	150	7	10
2	30	4	5
2	50	5	7
2	100	6	9
2	150	8	11
3	30	4	5
3	50	6	8
3	100	7	10
3	150	9	12
4	30	4	6
4	50	6	9
4	100	8	11
4	150	9	13

10.3.2.4 Determining the bracing thickness for the WWR1160 and WWR1200 installation size

Adapter plate: APWER3064			
Number of products	Pressure [bar]	Bracing thickness [mm]	
		Steel	Aluminum
1	30	7	10
1	50	10	15
1	100	12	18
1	150	15	22
2	30	7	11
2	50	11	17
2	100	14	20
2	150	17	25
3	30	8	12
3	50	12	18
3	100	15	22
3	150	18	27
4	30	9	13
4	50	14	20
4	100	17	25
4	150	20	30

Adapter plate: APWER 3062			
Number of products	Pressure [bar]	Bracing thickness [mm]	
		Steel	Aluminum
1	30	5	7
1	50	7	11
1	100	8	14
1	150	10	16
2	30	6	9
2	50	8	14
2	100	10	17
2	150	12	20

10.4 Installing the energy supply

10.4.1 Electrical products

NOTICE



Material damage and malfunction in case of non-compliance

The cable mounted on the product can be subjected to a torsional angle of +50°.

- ▶ Do not route the cable so that it is strained.
- ▶ You must meet the minimum bending radius of 10x the outer diameter.
- ▶ Secure free-hanging cables to prevent excessive motion loads or pinching.
- ▶ The contacts of the energy supply must be dry, clean and undamaged at all times.

INFORMATION



- ▶ If necessary, install the energy supply for electrical products before installing the product on the tool changer.

INFORMATION



- ▶ You can find the information about round plugs on the technical data sheet on our website.

- ▶ Connect the cables to the product using a round plug.

10.4.2 Hydraulic products

INFORMATION



- ▶ You can find the information about connecting threads on the technical data sheet on our website.

- ▶ Connect the products to the power supply using connecting threads.
 - ▶ Make sure that the pressure class is correct when selecting suitable hoses.

10.4.3 Pneumatic products

INFORMATION



- ▶ You can find the information about connecting threads on the technical data sheet on our website.

When they are coupled, pneumatic products seal using the pre-load of the seal. The pre-load is ensured by having the elements at a defined distance from each other.

- ▶ Connect the products to the power supply using connecting threads.
 - ▶ Make sure that the pressure class is correct when selecting suitable hoses.

10.5 Encoding the energy elements

INFORMATION



- ▶ For the encoding table, refer to the wiring diagram on the technical data sheet on our website.
- ▶ You can find the pin numbers on the technical data sheet on our website.

The encoding makes it possible to differentiate between differently equipped loose parts by means of consecutive numbering.

The encoding can be read out in binary fashion via contacts 1 to 4 on the round plug.

- ▶ Remove the mounting screws.
- ▶ Remove the cover.
- ▶ Set the rotary switch to the corresponding number using a suitable slotted screwdriver.
- ▶ Reinstall the cover on the product using the mounting screws.

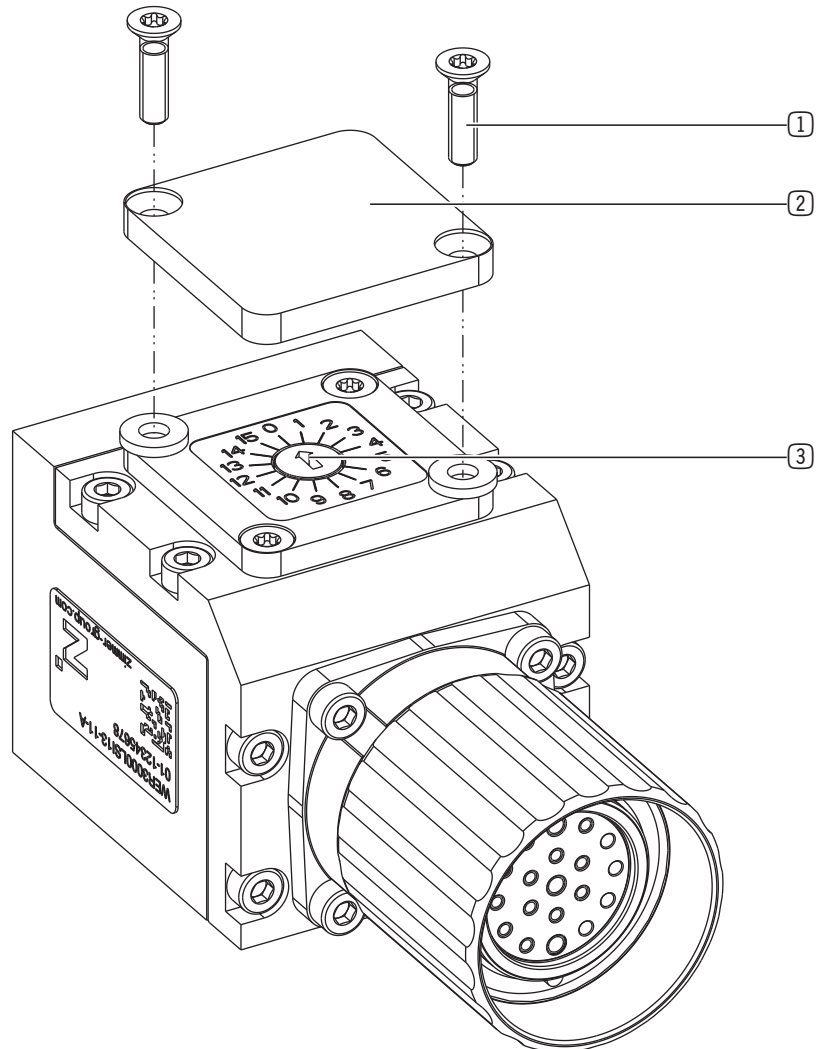

- ① Mounting screw
- ② Cover
- ③ Rotary switch

10.6 Installing the protective elements

NOTICE



Non-compliance may result in material damage.

Expose the contacts and/or contact surfaces in the decoupled state. Protective elements are necessary to protect products that are temporarily not being used.

- ▶ While the products are uncoupled, protect them from dirt from the outside.

For electrical products, the side with the pocket for the contacts must point in the direction of the product to be protected. For pneumatic products, the flat side must point in the direction of the element to be protected.

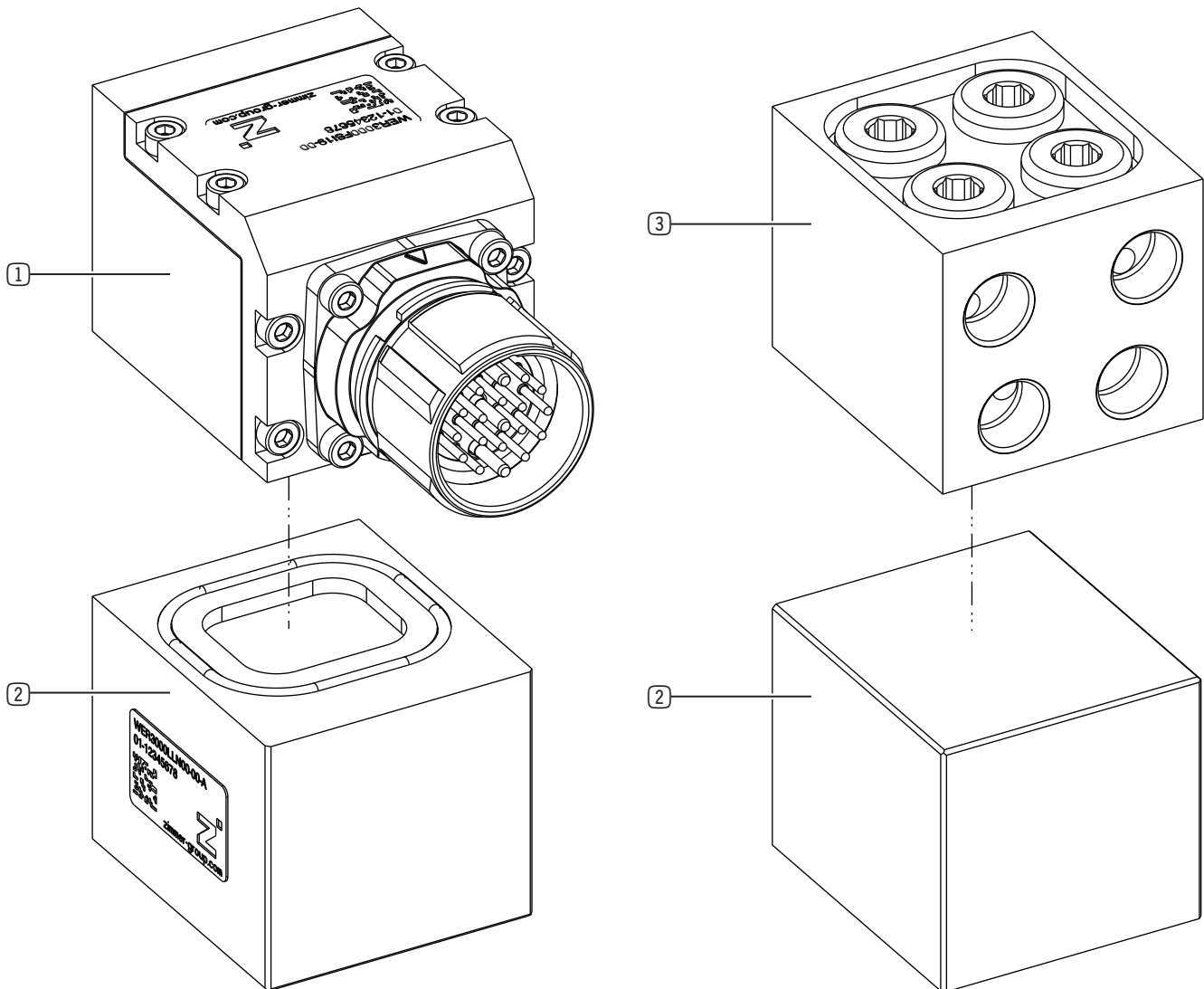

- ① Electrical stationary part
- ② Protective element
- ③ Pneumatic stationary part

10.7 Installing the sensors

NOTICE



Non-compliance may result in material damage.

Cables must be installed with sufficient length.

► Ensure that the cables cannot be pinched, crushed, or torn off within the movement and swivel ranges.

INFORMATION



For example, the WER3000FSI14-01-A and WER3000FSI14-02-A product variants are products with a direct connection for a piston position sensor and a loose part presence query.

The orientation of the round plug on the product can be changed.

- Loosen the lock nut.
- Turn the round plug to the desired position.
- Retighten the lock nut.
- Install the sensors.

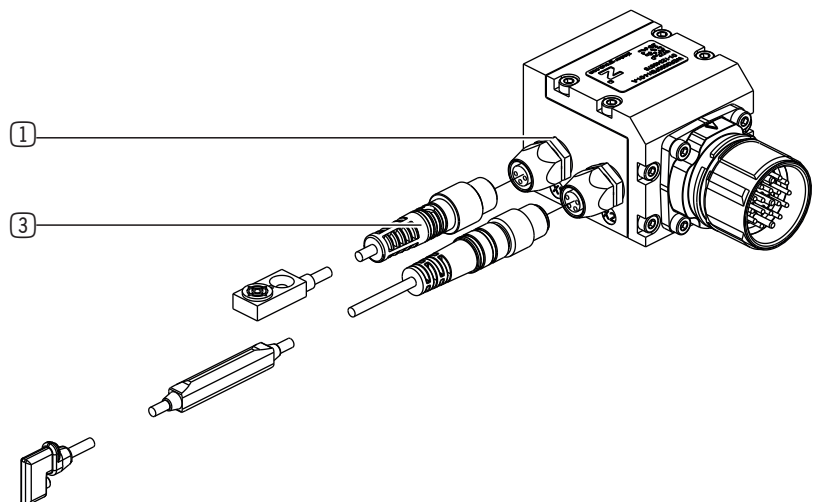
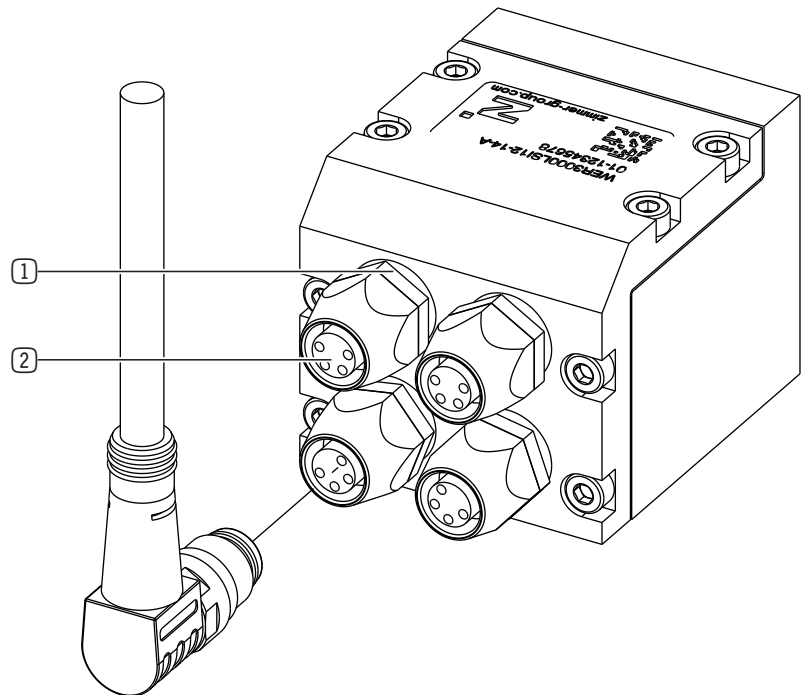

- ① Lock nut
- ② Round plug
- ③ Sensor

11 Maintenance

NOTICE



Material damage resulting from blowing out with compressed air

Blowing out the product with compressed air can cause malfunctions.

- ▶ Never purge the product with compressed air.

NOTICE



Material damage caused by unsuitable cleaning materials

Seals, insulation, coatings and other surfaces may be damaged by solvent-based cleaning agents.

- ▶ Make sure that no liquids penetrate the product.
- ▶ Use chemically and biologically neutral cleaning agents.
- ▶ Use cleaning agents that are categorized as being nonhazardous to health.
- ▶ Use soft, lint-free cloths for cleaning the surface.

The use of the following cleaning agents is strictly prohibited:

- Acetone
- Cleaning solvent
- Nitrocellulose thinner/turpentine oil (solvents)

NOTICE



Material damage caused by sharp-edged tools

Hard scrubbers, brushes or blades can damage contacts and flat surfaces.

- ▶ Do not clean the product using any sharp-edged tools.

NOTICE



Non-compliance may result in material damage.

- ▶ Perform regular leak tests on pneumatic and fluidic products.
- ▶ Replace leaky component parts immediately.

Maintenance-free operation of the product is guaranteed for a specified number of cycles.

Transmission type	Mating cycles
Electrical with plug contacts ≤ 15 A	1 million
Electrical with plug contacts > 15 A	100,000
Electrical with spring contacts ≤ 3 A	1 million
Hydraulic with operating pressure up to max. 150 bar	1 million
Pneumatic	5 million

- ▶ Note that the product could become damaged under the following circumstances:
 - Operation with impermissible compressed air
 - Dirty environment
 - Improper use and use that does not comply with the performance data
 - Permissible temperature range not observed
- ▶ Even though the product is maintenance-free as mentioned above, perform a regular visual inspection to check for any damage or contamination.
- ▶ Have maintenance work that requires disassembly of the product performed by customer service only.
- ⇒ Dismantling and reassembling the product without authorization may result in complications, as special installation equipment is required in some cases. Zimmer Group GmbH accepts no liability for any resulting malfunctions or damage.

12 Decommissioning/disposal

INFORMATION



When the product reaches the end of its operational phase, it can be completely disassembled and disposed of.

- ▶ Disconnect the product completely from the power supply.
- ▶ Dispose of the components properly according to the material groups.
- ▶ Comply with the locally applicable environmental and disposal regulations.

13 RoHS declaration

in terms of the EU Regulation 2011/65/EU

Name and address of the manufacturer:

Zimmer Group GmbH

Am Glockenloch 2
77866 Rheinau, Germany

+49 7844 9138 0

info@zimmer-group.com

www.zimmer-group.com

We hereby declare that the incomplete machine described below

Product designation: Energy elements

Type designation: WER3000

conforms to the requirements of the directive in its design and the version we put on the market.

Michael Hoch

Authorized representative for the
compilation of relevant technical
documents

Rheinau, Germany, 2021-08-20

(Place and date of issuance)

Martin Zimmer
(Legally binding signature)
Managing Partner

14 Declaration of Incorporation (Machinery Directive)

In terms of the EU Machinery Directive 2006/42/EC (Annex II 1 B)

Name and address of the manufacturer:

Zimmer Group GmbH

 Am Glockenloch 2
77866 Rheinau, Germany

 +49 7844 9138 0

 info@zimmer-group.com

 www.zimmer-group.com

We hereby declare that the incomplete machine described below

Product designation: Energy elements

Type designation: WER3000

conforms to the requirements of the Machinery Directive, 2006/42/EC, Article 2g, Annex VII, b – Annex II, b, in its design and the version we put on the market.

We hereby confirm that all the relevant basic health and safety requirements for the product have been observed and implemented.

A full list of applied standards can be obtained from the manufacturer.

We also declare that the specific technical documents were produced in accordance with Annex VII Part B of this Directive. We undertake to provide the market supervisory bodies with electronic versions of special documents for the incomplete machine through our documentation department, should they have reason to request them.

The incomplete machine may only be commissioned if it has been ascertained, if applicable, that the machine or system in which the incomplete machine is to be installed satisfies the requirements of Directive 2006/42/EC on Machinery and an EC Declaration of Conformity has been drawn up in accordance with Annex II 1 A.

Kurt Ross

Authorized representative for the
compilation of relevant technical
documents

Rheinau, Germany, 2021-08-20

(Place and date of issuance)



Martin Zimmer
(Legally binding signature)
Managing Partner

15 Declaration of Incorporation

In terms of the EU Machinery Regulation 2023/1230, Annex V, Part B

Name and address of the manufacturer:

Zimmer Group GmbH

📍 Am Glockenloch 2
77866 Rheinau, Germany

☎ +49 7844 9138 0

✉ info@zimmer-group.com

🌐 www.zimmer-group.com

We hereby declare that the incomplete machine described below

Product designation: Energy elements

Type designation: WER3000

conforms to the requirements of the Regulation 2023/1230, Article 3.10, Annex III, Annex IV Part B, Annex V Part B, in its design and the version we put on the market.

A complete list of the standards applied and the essential safety and health protection requirements is available from the manufacturer.

The incomplete machine may only be commissioned if it has been ascertained, if applicable, that the machine or system in which the incomplete machine is to be installed satisfies the requirements of the EU Machinery Regulation 2023/1230 and an EC Declaration of Conformity has been drawn up in accordance with Annex V, Part A.

Kurt Ross

Authorized representative for the compilation of relevant technical documents

Rheinau, Germany, 2027-01-20

(Place and date of issuance)



Martin Zimmer
(Legally binding signature)
Managing Partner

16 Declaration of Conformity

In terms of the EU Directive 2014/35/EU (Low voltage directive)

Name and address of the manufacturer:

Zimmer Group GmbH

Am Glockenloch 2
77866 Rheinau, Germany

+49 7844 9138 0

info@zimmer-group.com

www.zimmer-group.com

We hereby declare that the product described below

Product designation: Energy elements

Type designation: WER3000FSI12-00, WER3000LSI12-00, WER3000FLA01-27-A, WER3000LLA01-27-A, WER3000FLA06-00, WER3000LLA06-00, WER3000FLA08-00, WER3000LLA08-00, WER3000FSI11-20-A, WER3000LSI11-20-A

conforms to the requirements of the 2014/35/EC directive in its design and the version we put on the market.

The following harmonized standards have been used:

DIN EN ISO 12100	Safety of machinery - General principles for design - Risk assessment and risk reduction
DIN EN 60204-1	Safety of machinery - Electrical equipment of machines - Part 1: General requirements

A full list of applied standards can be obtained from the manufacturer.

Kurt Ross

Authorized representative for the compilation of relevant technical documents

Rheinau, Germany, 2021-08-20

(Place and date of issuance)



Martin Zimmer
(Legally binding signature)
Managing Partner