

INSTALLATION AND OPERATING INSTRUCTIONS

2-jaw parallel gripper

HRC-03

I/O

DDOC01810

THE KNOW-HOW FACTORY

Content

| | | |
|---------|--|----|
| 1 | Introduction | 4 |
| 1.1 | Supporting documents | 4 |
| 1.2 | Notices and graphics in the instructions | 4 |
| 2 | Safety notices | 5 |
| 3 | Proper use | 6 |
| 4 | Personnel qualification | 7 |
| 4.1 | Electricians | 7 |
| 4.2 | Specialists | 7 |
| 4.3 | Instructed personnel..... | 7 |
| 4.4 | Service personnel..... | 7 |
| 4.5 | Additional qualifications | 7 |
| 5 | Product description | 8 |
| 5.1 | Possible applications..... | 8 |
| 5.2 | Type plate | 8 |
| 5.3 | Use in applications | 9 |
| 6 | Functional description | 10 |
| 6.1 | LED status display | 10 |
| 7 | Technical data | 11 |
| 8 | Accessories/scope of delivery | 11 |
| 9 | Transportation/storage/preservation | 11 |
| 10 | Installation | 12 |
| 10.1 | Installing the product..... | 13 |
| 10.2 | Installing HRC-03-117137..... | 14 |
| 10.3 | Installing HRC-03-125035..... | 15 |
| 10.4 | Installing the energy supply | 16 |
| 10.4.1 | HRC-03-100688 pin assignment..... | 17 |
| 10.4.2 | HRC-03-116787 pin assignment..... | 17 |
| 10.4.3 | HRC-03-117137 pin assignment..... | 17 |
| 10.4.4 | HRC-03-118505 pin assignment..... | 18 |
| 10.4.5 | HRC-03-118506 pin assignment..... | 18 |
| 10.4.6 | HRC-03-125035 pin assignment..... | 18 |
| 10.4.7 | HRC-03-126649 pin assignment..... | 19 |
| 10.4.8 | HRC-03-126895 pin assignment..... | 19 |
| 10.4.9 | HRC-03-126897 pin assignment..... | 19 |
| 10.4.10 | HRC-03-133316 pin assignment..... | 20 |
| 10.4.11 | HRC-03-148656 pin assignment..... | 20 |
| 10.4.12 | HRC-03-151986 pin assignment..... | 20 |
| 10.5 | Switch between PNP and NPN | 21 |
| 10.6 | Static charge | 22 |
| 10.7 | Heat dissipation | 22 |
| 10.8 | Installing accessories | 22 |
| 11 | Commissioning | 23 |
| 11.1 | Restart | 23 |
| 11.2 | Switching sequence | 23 |
| 11.2.1 | Current profile during the gripping process..... | 25 |
| 11.3 | Minimum positioning path | 25 |
| 12 | Operation..... | 26 |
| 12.1 | Operating Freedrive..... | 26 |

| | | |
|------|-----------------------------------|----|
| 12.2 | Setting the gripping force..... | 27 |
| 12.3 | Emergency release..... | 27 |
| 13 | Gripping force charts..... | 28 |
| 14 | Error diagnosis..... | 28 |
| 14.1 | Status of the LED display..... | 28 |
| 15 | Maintenance..... | 29 |
| 16 | Decommissioning/disposal..... | 29 |
| 17 | RoHS declaration..... | 30 |
| 18 | Declaration of Incorporation..... | 31 |
| 19 | Declaration of Conformity..... | 32 |

1 Introduction

1.1 Supporting documents

NOTICE



Read through the instructions before installing or working with the product.

The instructions contain important notes for your personal safety. They must be read and understood by all persons who work with or handle the product during any phase of the product lifetime.



The documents listed below are available for download on our website www.zimmer-group.com.

- Instructions
 - Catalogs, drawings, CAD data, performance data
 - Information on accessories
 - Technical data sheets
 - General Terms and Conditions, including warranty information.
- ⇒ Only those documents currently available on the website are valid.

In these instructions, "product" refers to the product designation on the title page!

1.2 Notices and graphics in the instructions

DANGER



This notice warns of an imminent danger to the life and health of people. Ignoring these notices can lead to serious injury or even death.

- ▶ You absolutely must comply with the described measures for avoiding these dangers!
- ⇒ The warning symbols are assigned according to the type of danger.

WARNING



This notice warns of a situation that is potentially hazardous to personal health. Ignoring these notices can cause serious injury or damage to health.

- ▶ You absolutely must comply with the described measures for avoiding these dangers!
- ⇒ The warning symbols are assigned according to the type of danger.

CAUTION



This notice warns of a situation that is potentially hazardous to persons. Ignoring these notices can cause minor, reversible injuries.

- ▶ You absolutely must comply with the described measures for avoiding these dangers!
- ⇒ The warning symbols are assigned according to the type of danger.

NOTICE



This notice warns of possible material and environmental damage. Ignoring these notices can result in damage to the product or the environment.

- ▶ You absolutely must comply with the described measures for avoiding these dangers!
- ⇒ The warning symbols are assigned according to the type of danger.

INFORMATION



This category contains useful tips for handling the product efficiently. Failure to observe these tips will not result in damage to the product. This information does not include any information relevant to health or workplace safety.

2 Safety notices

CAUTION



Risk of injury and material damage in case of non-compliance

The product is state-of-the-art.

The following are examples of situations in which the product may cause a hazard:

- The product is not properly installed, used or maintained.
- The product is not used for its designated purpose.
- The locally applicable regulations, laws, directives or guidelines are not observed.
- ▶ The product may only be used in accordance with these instructions and the product's technical data. Any changes or additions to the intended use of the product, as well as modifications to the product, such as those in the following examples, require the written permission of the manufacturer:
 - Use of the product under extreme conditions, such as aggressive fluids or abrasive dusts
 - Additional drilled holes or threads
- ⇒ Zimmer Group GmbH shall accept no liability for any damage caused by improper use. The operator bears sole responsibility.
- ▶ Make sure that the power supply is disconnected before you mount, adjust, modify, maintain or repair the product.
- ▶ Whenever work is carried out on the product, make sure that the product cannot be actuated by mistake.
- ▶ Perform maintenance tasks, renovation work or attachment work outside of the machine's danger zone when possible.
- ▶ Do not reach into the operational range of the product.
- ▶ Always adhere to the required maintenance intervals.
- ▶ When using the product under extreme conditions, adjust the maintenance interval according to the degree of contamination.
- ▶ Check the completeness and tightening torques of all mounting screws.

The suitability of the product for collaborative use can only be verified while using gripper fingers installed in factory condition.

- ▶ If using other gripper fingers, check the permitted maximum force and pressure values for collaborative operation.

CAUTION



Notes and handling regulations for electrostatically sensitive components

Electrostatically sensitive components are individual components, integrated circuits or assemblies that can be damaged by electrostatic fields or electrostatic discharge.

- ▶ When handling electrostatic components, make sure that persons, the work area and packaging are all fully grounded.
- ▶ Touch electronic components only in appropriately identified areas with conductive flooring and only if:
 - You are grounded by means of special bracelets.
 - You wear shoes that are suitable and approved for the discharge of electrostatic charges.
- ▶ Do not bring electronic assemblies into contact with plastics and parts of clothing that have plastic content.
- ▶ Store electronic assemblies on conductive underlays only.
- ▶ Do not install electronic assemblies in the vicinity of data back-up devices or monitors (monitor distance > 100 mm).
- ▶ Perform measurements on electronic assemblies only if:
 - The measuring instrument is grounded (e.g. via a ground conductor).
 - The measuring head is momentarily discharged before measuring with a floating measuring instrument.

3 Proper use

NOTICE



Material damage and malfunction in case of non-compliance

The product is only to be used in its original state with its original accessories, with no unauthorized changes and within the stipulated parameter limits and operating conditions.

Any other or secondary use is deemed improper.

- ▶ Operate the product only in compliance with the associated instructions.
 - ▶ Operate the product only when it is in a technical condition that corresponds to the guaranteed parameters and operating conditions.
- ⇒ Zimmer Group GmbH shall accept no liability for any damage caused by improper use. The operator bears sole responsibility.

- The product is to be used as intended in enclosed rooms for temporary gripping, handling and holding.
- The product is intended for industrial use.
- The product is not suited for use in a potentially explosive atmosphere.
- Direct contact with perishable goods/food is not permitted.
- The product must always be mounted on materials that dissipate heat.
- The product is not suitable for clamping workpieces during a machining process.
- The product is designed exclusively for electric operation using a 24 V DC power supply.

4 Personnel qualification

WARNING



Inadequate qualification can cause injury and material damage

If inadequately qualified personnel perform work on the product, this can cause serious injuries and significant material damage.

- ▶ All work on the product must be performed by qualified personnel.
- ▶ Before working with the product, read the document in its entirety and make sure that you have understood everything.
- ▶ Observe country-specific accident prevention regulations and the general safety notices.

The following qualifications are a prerequisite for performing various work on the product.

4.1 Electricians

Electricians are able to perform work on electrical systems, can recognize and avoid possible dangers and know the relevant standards and provisions due to their technical training, knowledge and experience.

4.2 Specialists

Specialists are able to perform the assigned work, can recognize and avoid possible dangers and know the relevant standards and provisions due to their technical training, knowledge and experience.

4.3 Instructed personnel

Instructed personnel have been trained by the operating company on the tasks and possible dangers of improper behavior.

4.4 Service personnel

Service personnel are able to perform the assigned work and can recognize and avoid possible dangers due to their technical training, knowledge and experience.

4.5 Additional qualifications

Persons who work with the product must be familiar with the valid safety regulations and laws as well as the standards, guidelines and laws listed in this document.

Personnel who work with the product must have facility-issued authorization to commission, program, configure, operate, maintain and also decommission this product.

5 Product description

5.1 Possible applications

Outside gripping

The product can be used for outside gripping.
MoveToWork command

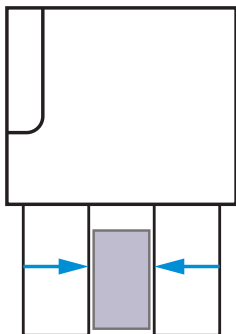

Inside gripping

The product can be used for inside gripping.
MoveToBase command

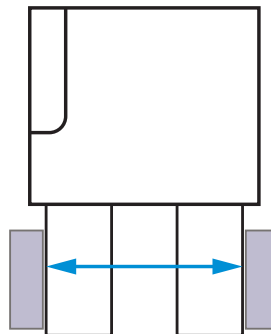

5.2 Type plate

A type plate is attached to the product.

- ① Article number
- ② Confirmation number

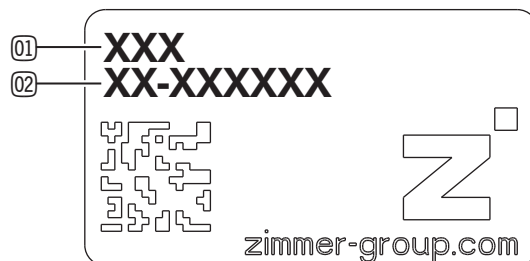

5.3 Use in applications

The criteria listed below justify the suitability of the product for use in collaborative applications:

- The product has been designed in accordance with the specifications of ISO/TS 15066.
- The torque of the motor in combination with the transmission design and the pre-assembled gripper jaws is not sufficient to generate a gripping force > 140 N upon vulnerable areas of the body.
- The gripping forces generated when gripping soft objects are significantly reduced, since the amount of dynamic force is lowered. Compliance with the maximum permitted gripping force has been verified by a suitable measuring instrument.
- The product is engineered to be inherently safe and is designed with rounded edges and shapes that prevent crushing and shearing points from being created.

Automation cell

Separated workspaces



Coexistence

Detection of presence

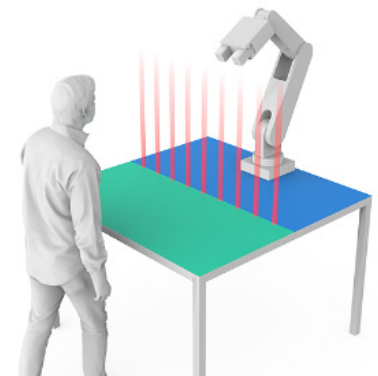

Cooperation

Zones of action

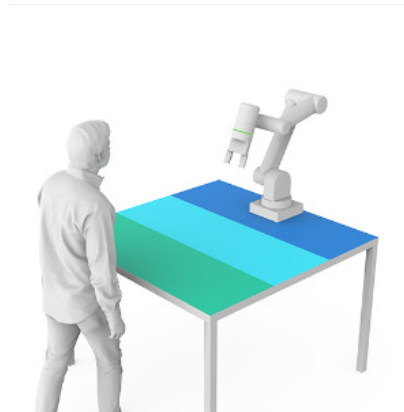

Collaboration

Shared workspaces

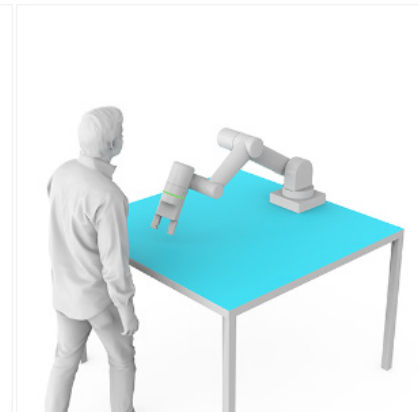

6 Functional description

The gripper jaws of the product are arranged parallel to each other on two opposing guide rails and can be moved relative to each other.

The force of the motor is transmitted over a gear to a worm gear. The movement is transferred from the worm gear to the toothed gripper jaws and a synchronized movement is generated.

The product has a mechanical self-locking mechanism to ensure that the workpiece remains held in the event of a power supply loss.

The product can be integrated into available control systems and controlled via digital inputs and outputs.

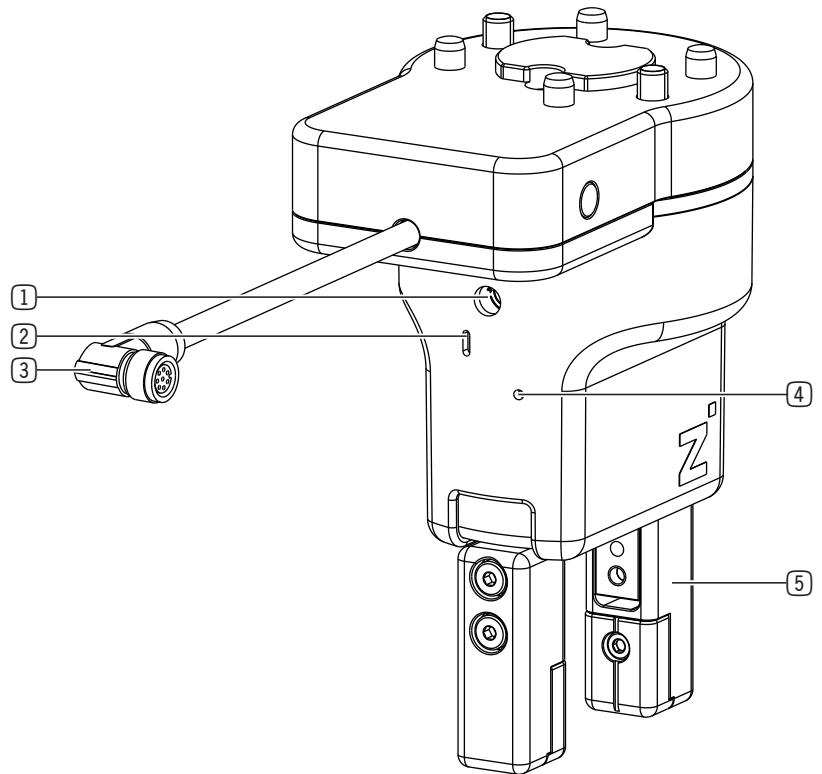

- ① Setting the gripping force
- ② LED display
- ③ Power supply
- ④ Emergency release
- ⑤ Gripper jaw

6.1 LED status display

- ① Power/communication
- ② Error

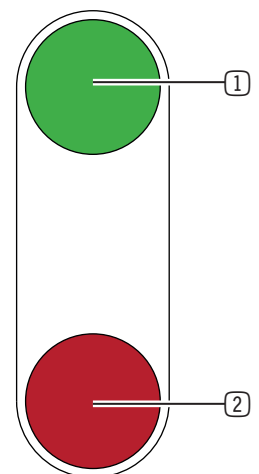

7 Technical data

INFORMATION



- ▶ You can find the information in the technical data sheet on our website.
- ▶ This data varies within the series, depending on the specific design.

8 Accessories/scope of delivery

INFORMATION



- ▶ If any accessories not sold or authorized by Zimmer Group GmbH are used, the function of the product cannot be guaranteed. Zimmer Group GmbH accessories are specifically tailored to the individual products.
- ▶ For optional accessories and those included in the scope of delivery, refer to our website.

9 Transportation/storage/preservation

- ▶ Transport and storage of the product must be done only with the original packaging.
- ▶ If the product has already been installed on the superordinate machine unit, care must be taken during transport to ensure that no unexpected movements can occur.
 - ▶ Before commissioning the product and after transport, check all power and communication connections as well as all mechanical connections.
- ▶ If the product is stored for an extended period, the following points are to be observed:
 - ▶ Keep the storage location as dust-free and dry as possible.
 - ▶ Avoid temperature fluctuations.
 - ▶ Avoid wind/drafts/water condensation formation.
 - ▶ Pack the product and do not expose it to direct sunlight during storage.
- ▶ Clean all components. There must be no soiling left on the components.
- ▶ Visually inspect all components.
- ▶ Remove all foreign substances.
- ▶ Properly remove potential corrosion spots.
- ▶ Close electrical connections using suitable covers.

10 Installation

WARNING



Risk of injury due to uncontrolled movements

Risk of injury in case of unexpected movement of the machine or system into which the product is to be installed.

- ▶ Switch off the energy supply of the machine before any work.
- ▶ Secure the power supply against being switched on unintentionally.
- ▶ Check the machine for any residual energy that may be present.

CAUTION



Risk of injury due to uncontrolled movements

Risk of injury in the event of uncontrolled movement of the product when the power supply is connected.

- ▶ Switch off the power supply to the machine before carrying out any work.
- ▶ Secure the power supply against being switched on unintentionally.
- ▶ Check the machine for any residual energy that may be present.

INFORMATION



Further installation information:

- The mounting screws are not included in the scope of delivery.

Assembly requirements

| | |
|---------------------------------------|------|
| Permissible flatness tolerance [mm] | 0,03 |
| Strength class of the mounting screws | 8.8 |

- ▶ Install the product on an appropriate mounting surface in accordance with the flatness specifications.
- ▶ Make sure that the mounting piece is sufficiently rigid.
- ▶ Ensure the cleanliness of the connection surfaces.
- ▶ Please note the permitted tightening torques of the mounting screws at www.zimmer-group.com/en/td.

10.1 Installing the product

INFORMATION



- ▶ Use an adapter plate if necessary.
- ▶ For information on optional accessories and those included in the scope of delivery, refer to our website.

- ▶ Remove the countersunk screws.
- ▶ Remove the housing.
- ▶ Position the product on the mounting piece with the straight pins.
- ▶ Mount the product on the mounting piece with the mounting screws.
- ▶ Install the housing using the countersunk screws.

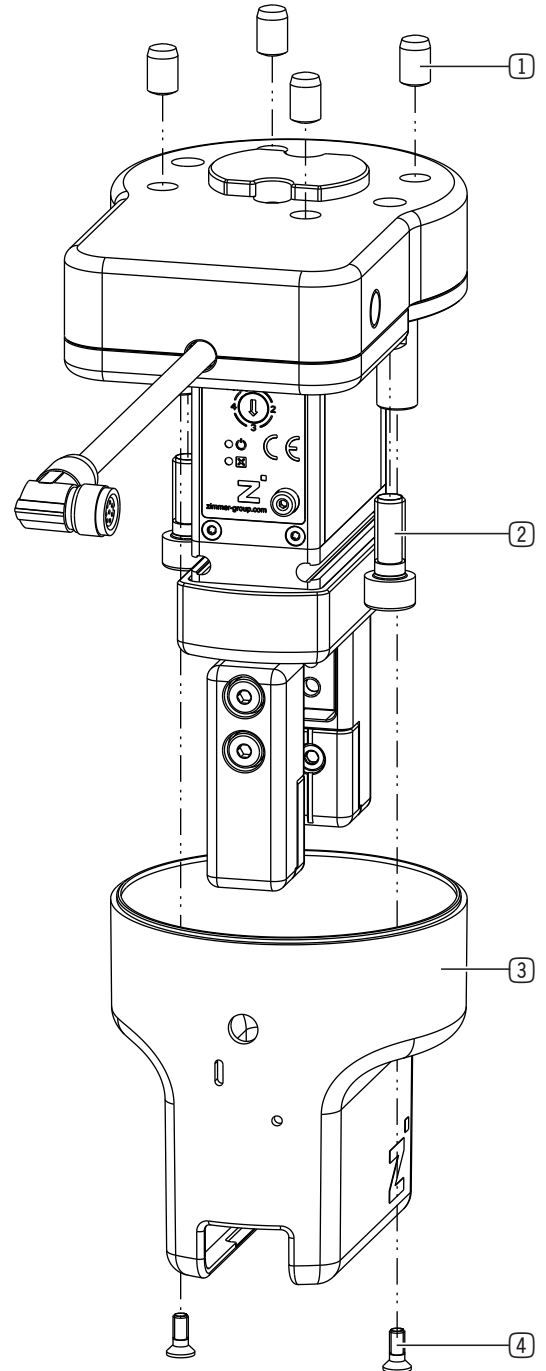

- ① Straight pins
- ② Mounting screw
- ③ Case
- ④ Countersunk screw

10.2 Installing HRC-03-117137

INFORMATION



► For more information on the “ClickSmart” plate, please see the technical data sheet from the manufacturer.

- Position the “ClickSmart” plate on the product.
- Loosely attach the mounting screws.
- Tighten the mounting screws without distortion.

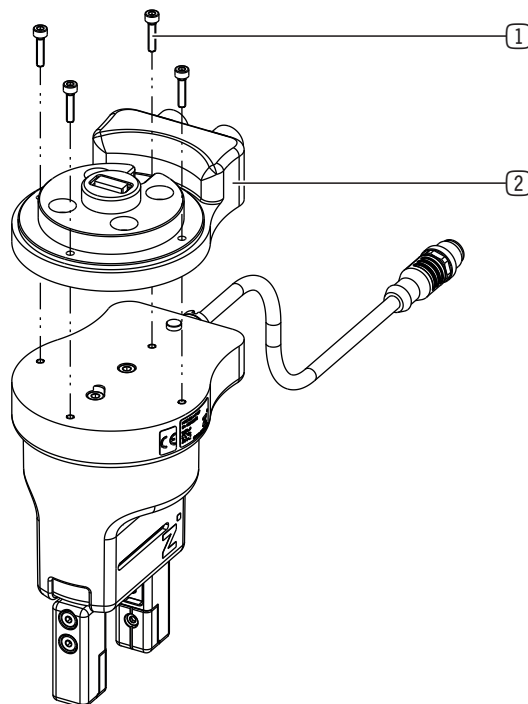

- ① Mounting screw
- ② “ClickSmart” plate

10.3 Installing HRC-03-125035

- ▶ Remove the countersunk screws.
- ▶ Remove the housing.
- ▶ Remove the mounting screws.
- ▶ Remove the adapter plate.
- ▶ Position the adapter plate on the mounting piece using the straight pin.
- ▶ Install the adapter plate on the mounting piece using the mounting screws.
- ▶ Position the product on the adapter plate using the straight pin.
- ▶ Mount the product on the adapter plate using the mounting screws.
- ▶ Install the housing using the countersunk screws.

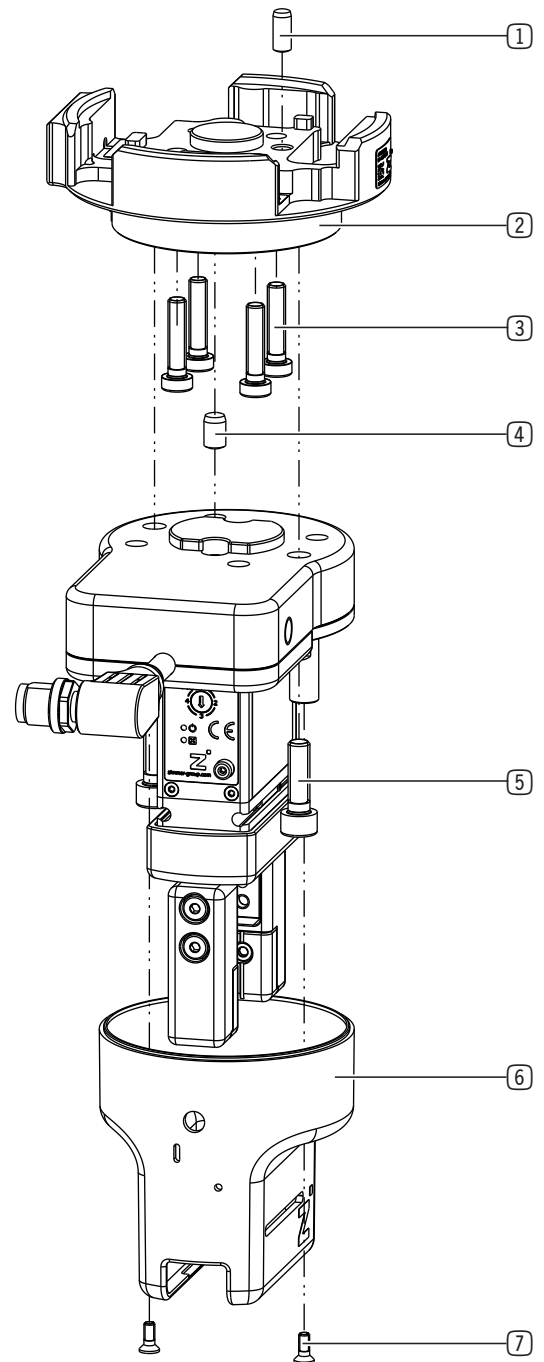

- ① Adapter plate straight pin
- ② Adapter plate
- ③ Adapter plate mounting screw
- ④ Straight pins
- ⑤ Mounting screw
- ⑥ Case
- ⑦ Countersunk screw

10.4 Installing the energy supply

CAUTION



Risk of injury and material damage in case of non-compliance

Incorrect pin assignment can lead to malfunction or destruction of the product.

- ▶ Be absolutely certain to ensure correct pin assignment.

NOTICE



Material damage and malfunction in case of non-compliance

The cable mounted on the product can be subjected to a torsional angle of $+50^\circ$.

- ▶ Do not route the cable so that it is strained.
- ▶ You must meet the minimum bending radius of 10x the outer diameter.
- ▶ Secure free-hanging cables to prevent excessive motion loads or pinching.
- ▶ The contacts of the energy supply must be dry, clean and undamaged at all times.

- ▶ Connect the power supply cable to the control system of the product.

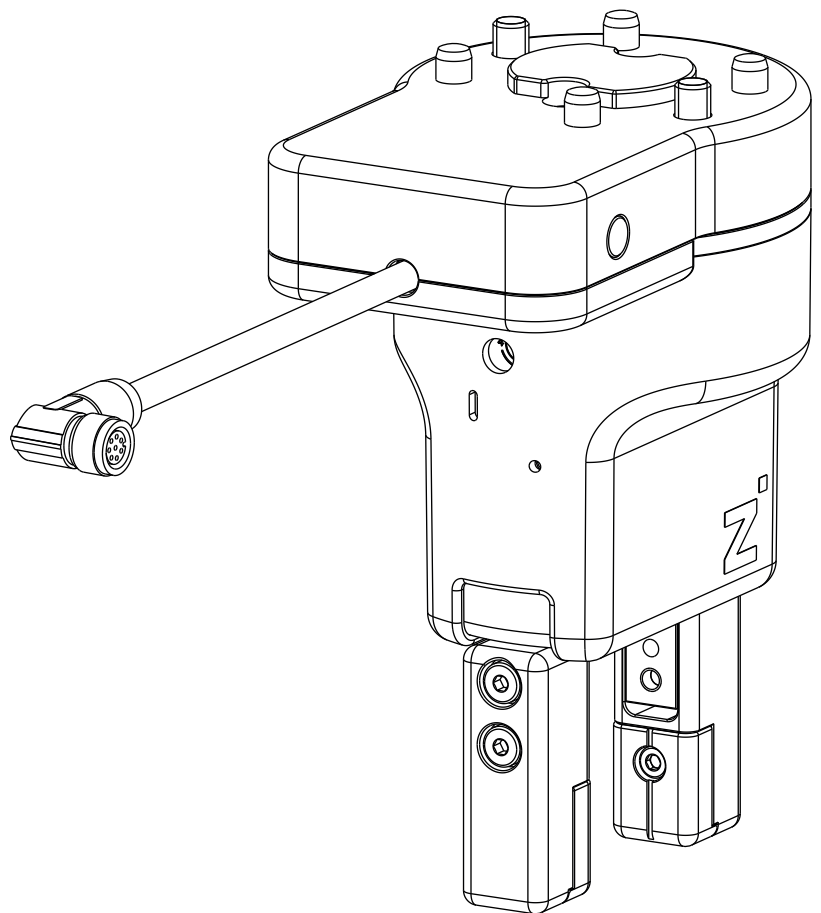

10.4.1 HRC-03-100688 pin assignment

| Pin | Color | Function | Explanation | Socket, M8 |
|-----|--------|-----------------|---|------------|
| 1 | White | PWR | 0 V DC supply voltage | |
| 2 | Brown | Digital input 1 | 24 V DC supply voltage | |
| 3 | Green | GND | Outward move command: Jaws move outward | |
| 4 | Yellow | Digital input 2 | Inward move command: Jaws move inward | |
| 5 | - | - | - | |
| 6 | - | - | - | |
| 7 | - | - | - | |
| 8 | Red | Analog output | Jaw position 0–10 V DC | |

The inputs of the product are configured for NPN outputs of the control system.

10.4.2 HRC-03-116787 pin assignment

| Pin | Color | Function | Explanation | Socket, M8 |
|-----|-------|-----------------|---|------------|
| 1 | White | Analog output | Jaw position 0–10 V DC | |
| 2 | - | - | - | |
| 3 | - | - | - | |
| 4 | - | - | - | |
| 5 | Gray | PWR | 24 V DC supply voltage | |
| 6 | Pink | Digital input 1 | Inward move command: Jaws move inward | |
| 7 | Blue | Digital input 2 | Outward move command: Jaws move outward | |
| 8 | Red | GND | 0 V DC supply voltage | |

The product inputs are designed for PNP outputs of the control system with a supply voltage of 24 V DC.

10.4.3 HRC-03-117137 pin assignment

| Pin | Color | Function | Explanation | Plug, M8 |
|-----|--------|------------------|---|----------|
| 1 | White | PWR | 24 V DC supply voltage | |
| 2 | Brown | Digital input | 0 V DC = Outward move command: Jaws move outward 24 V DC = Inward move command: Jaws move inward | |
| 3 | Green | GND 1 | 0 V DC supply voltage | |
| 4 | Yellow | Analog output | Analog value | |
| 5 | Gray | GND 2 | GND | |
| 6 | Pink | Digital output 1 | BasePosition (jaws outward) | |
| 7 | Blue | Digital output 2 | WorkPosition (jaws inward) | |
| 8 | Red | GND 3 | GND | |

The product inputs are designed for PNP outputs of the control system with a supply voltage of 24 V DC.

10.4.4 HRC-03-118505 pin assignment

| Pin | Color | Function | Explanation | Socket, M8 |
|-----|--------|-----------------|---|------------|
| 1 | White | Analog output | Jaw position 0–10 V DC | |
| 2 | - | - | - | |
| 3 | - | - | - | |
| 4 | Yellow | Digital output | Freedrive signal: 24 V DC if Freedrive button is pressed. | |
| 5 | Gray | PWR | 24 V DC supply voltage | |
| 6 | Pink | Digital input 2 | Inward move command: Jaws move inward | |
| 7 | Blue | Digital input 1 | Outward move command: Jaws move outward | |
| 8 | Red | GND | 0 V DC supply voltage | |

The inputs of the product are configured for NPN outputs of the control system.

10.4.5 HRC-03-118506 pin assignment

| Pin | Color | Function | Explanation | Plug, M8 |
|-----|--------|-----------------|---|----------|
| 1 | - | - | - | |
| 2 | Brown | Analog output | Jaw position 0–10 V DC | |
| 3 | Green | Digital input 1 | Outward move command: Jaws move outward | |
| 4 | Yellow | Digital input 2 | Inward move command: Jaws move inward | |
| 5 | Gray | PWR | 24 V DC supply voltage | |
| 6 | Pink | Digital output | Freedrive signal: 24 V DC if Freedrive button is pressed. | |
| 7 | - | - | - | |
| 8 | Red | GND | 0 V DC supply voltage | |

The inputs of the product are configured for NPN outputs of the control system.

10.4.6 HRC-03-125035 pin assignment

| Pin | Color | Function | Explanation | Plug, M12 |
|-----|--------|------------------|---|-----------|
| 1 | White | GND | 0 V DC supply voltage | |
| 2 | Brown | PWR | 24 V DC supply voltage | |
| 3 | Green | Digital input 1 | Outward move command: Jaws move outward | |
| 4 | Yellow | Digital input 2 | Inward move command: Jaws move inward | |
| 5 | - | - | - | |
| 6 | - | - | - | |
| 7 | Blue | Digital output 1 | BasePosition (jaws outward) | |
| 8 | Red | Digital output 2 | WorkPosition (jaws inward) | |

The product inputs are designed for PNP outputs of the control system with a supply voltage of 24 V DC.

10.4.7 HRC-03-126649 pin assignment

| Pin | Color | Function | Explanation | Socket, M8 |
|-----|--------|------------------|---|------------|
| 1 | White | Analog output | Jaw position 0–10 V DC | |
| 2 | - | - | - | |
| 3 | Green | Digital output 2 | WorkPosition (jaws inward) | |
| 4 | Yellow | Digital output 1 | BasePosition (jaws outward) | |
| 5 | Gray | PWR | 24 V DC supply voltage | |
| 6 | Pink | Digital input 1 | Inward move command: Jaws move inward | |
| 7 | Blue | Digital input 2 | Outward move command: Jaws move outward | |
| 8 | Red | GND | 0 V DC supply voltage | |

The product inputs are designed for PNP outputs of the control system with a supply voltage of 24 V DC.

10.4.8 HRC-03-126895 pin assignment

| Pin | Color | Function | Explanation | Plug, M8 |
|-----|-------|------------------|---|----------|
| 1 | White | Digital output 1 | BasePosition (jaws outward) | |
| 2 | Brown | Digital input 1 | Inward move command: Jaws move inward | |
| 3 | Green | Digital input 2 | Outward move command: Jaws move outward | |
| 4 | - | - | - | |
| 5 | Gray | PWR | 24 V DC supply voltage | |
| 6 | - | - | - | |
| 7 | Blue | Digital output 2 | WorkPosition (jaws inward) | |
| 8 | Red | GND | 0 V DC supply voltage | |

The product inputs are designed for PNP outputs of the control system with a supply voltage of 24 V DC.

10.4.9 HRC-03-126897 pin assignment

| Pin | Color | Function | Explanation | Plug, M8 |
|-----|-------|---------------|---|----------|
| 1 | Black | PWR | 24 V DC supply voltage | |
| 2 | - | - | - | |
| 3 | Brown | Digital input | 0 V DC = Outward move command: Jaws move outward 24 V DC = Inward move command: Jaws move inward | |
| 4 | White | Analog output | Jaw position 0–10 V DC | |
| 5 | Blue | GND | 0 V DC supply voltage | |

The inputs of the product are configured for NPN outputs of the control system.

INFORMATION



The product requires hardware release 3.0 or higher in order to function.

10.4.10 HRC-03-133316 pin assignment

| Pin | Color | Function | Explanation | Socket, M8 |
|-----|--------|------------------|---|------------|
| 1 | - | - | - | |
| 2 | - | - | - | |
| 3 | Green | Digital output 2 | BasePosition (jaws outward) | |
| 4 | Yellow | Digital output 1 | WorkPosition (jaws inward) | |
| 5 | Gray | PWR | 24 V DC supply voltage | |
| 6 | Pink | Digital input 2 | Outward move command: Jaws move outward | |
| 7 | Blue | Digital input 1 | Inward move command: Jaws move inward | |
| 8 | Red | GND | 0 V DC supply voltage | |

The inputs of the product are configured for NPN outputs of the control system.

10.4.11 HRC-03-148656 pin assignment

| Pin | Color | Function | Explanation | Socket, 0430200801 |
|-----|-------|------------------|---|--------------------|
| 1 | White | Digital input 1 | Outward move command: Jaws move outward | |
| 2 | Brown | Digital input 2 | Inward move command: Jaws move inward | |
| 3 | - | - | - | |
| 4 | - | - | - | |
| 5 | Gray | Digital output 1 | BasePosition (jaws outward) | |
| 6 | Pink | Digital output 2 | WorkPosition (jaws inward) | |
| 7 | Blue | PWR | 24 V DC supply voltage | |
| 8 | Red | GND | 0 V DC supply voltage | |

The product inputs are designed for PNP outputs of the control system with a supply voltage of 24 V DC.

10.4.12 HRC-03-151986 pin assignment

INFORMATION



Optionally, the ZUB000034 connecting cable is available as a connecting line for the ABB GoFa for OmniCore C30 control system.

► You can find information on our website.

| Pin | Color | Function | Explanation | Plug, M8 |
|-----|-------|----------|------------------------|----------|
| 1 | Brown | PWR | 24 V DC supply voltage | |
| 3 | Blue | GND | 0 V DC supply voltage | |
| 4 | - | - | - | |

| Pin | Color | Function | Explanation | Plug, M8 |
|-----|-------|------------------|---|----------|
| 1 | Brown | Digital input 2 | Outward move command: Jaws move outward | |
| 2 | White | Digital output 1 | BasePosition (jaws outward) | |
| 3 | Blue | Digital output 2 | WorkPosition (jaws inward) | |
| 4 | Black | Digital input 1 | Inward move command: Jaws move inward | |

The product inputs are designed for PNP outputs of the control system with a supply voltage of 24 V DC.

10.5 Switch between PNP and NPN

INFORMATION



The inputs and outputs of the product are preset customer-specifically to PNP or NPN.

- ▶ Remove the mounting screws using a Torx screwdriver.
 - ▶ Use wrench size TX10.
- ▶ Remove the cover.

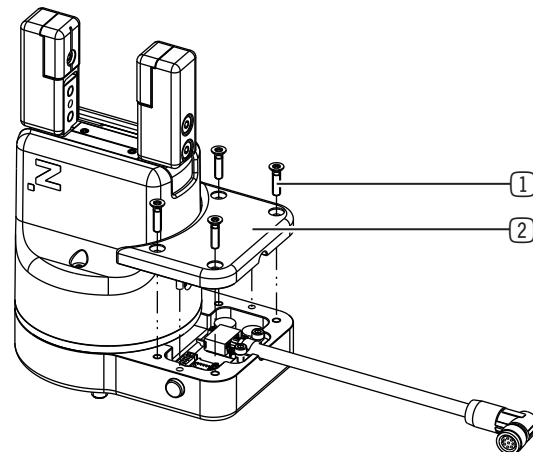

- ① Mounting screw
- ② Cover

- ▶ Plug in the jumpers.
- ▶ Install the cover with the mounting screws.

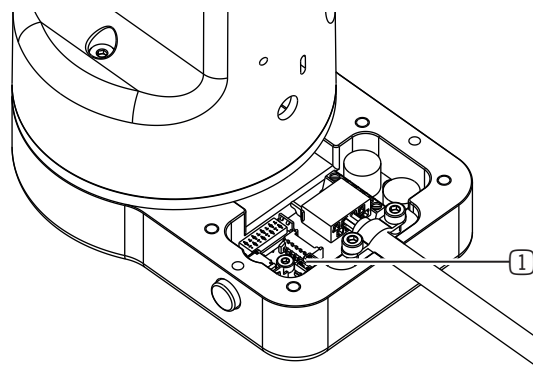

- ① Jumper

10.6 Static charge

NOTICE



Material damage from static charge

Electrostatic voltages can occur if the product is mounted on insulating surfaces and no effective dissipation of static charges is possible.

- ▶ Please note that ESD-sensitive parts can be damaged if they come into contact with the product.
- ▶ Ground the product for applications that require high EMC resistance.

10.7 Heat dissipation

NOTICE



Material damage from overheating of the product

If the product is operated under a very high ambient temperature or with fast clock cycles on an ongoing basis, this can reduce its service life.

- ▶ If the product is exposed to high ambient temperatures, always install it on heat-conducting materials.
- ▶ Reduce the load with increasing temperature.

10.8 Installing accessories

NOTICE



Non-compliance may result in material damage.

- ▶ Before installing an accessory, make sure it is suitable for use with the selected variant.
- ▶ You can find information on our website.
- ▶ Please contact Customer Service if you have any questions.

11 Commissioning

WARNING



Suspended loads can cause injury

Falling loads can cause severe injuries.

- ▶ Always keep an adequate safety distance from suspended loads.

CAUTION



Reduction of the gripping force can cause injury and material damage

When flexible components are gripped, the gripping force of the product is reduced.

Reduced gripping force can cause injuries or material damage because the components can no longer be securely gripped and transported.

- ▶ Always keep an adequate safety distance from suspended loads.

NOTICE



Malfunction in case of non-compliance

- ▶ Note the correct setting of the gripping force and the selection of the gripper finger length to prevent the gripper jaws from tensioning.

11.1 Restart

NOTICE



- ▶ Make sure that there is no signal present at digital inputs 1 and 2 when the product is restarted.
- ⇒ The product is ready to operate when the green LED lights up.
- ⇒ The product can be moved a few milliseconds after voltage is supplied.

11.2 Switching sequence

A movement in the desired direction occurs when the corresponding signal is at a high level. After a high level is detected, the gripper movement occurs until the gripping process ends.

- ▶ Reset the corresponding signal after the movement is complete. The signal must be reset before a signal is emitted in the opposite direction.
- ▶ Observe a break time of 10 ms between the reset of the signal and the next command.

INFORMATION



The following figure shows the controller for PNP.

When controlling for NPN, the command starts at low level instead of high level.

The current jaw position is scaled from 0 V DC (external) to 10 V DC (internal) and is issued via the analog output.

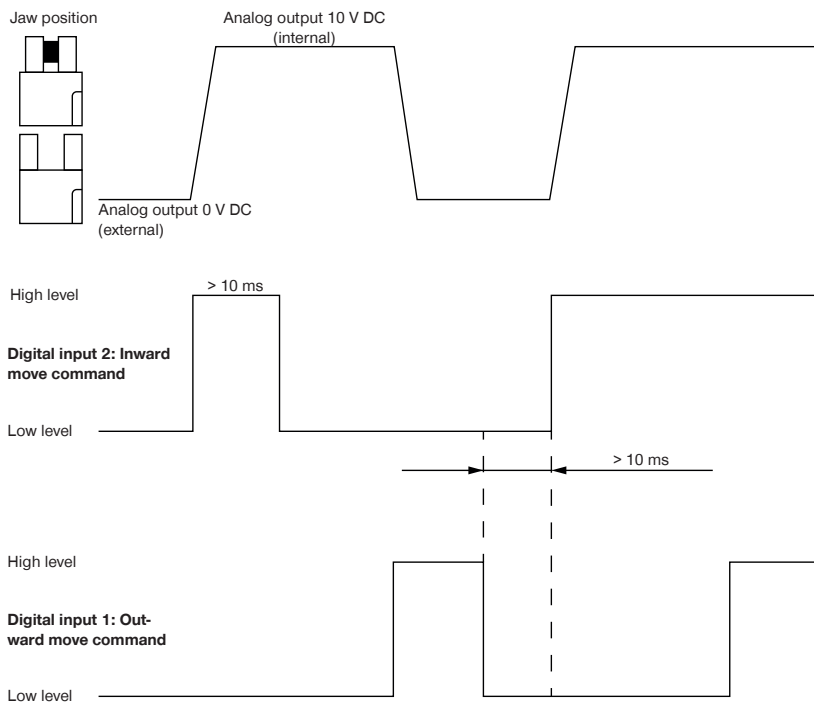

11.2.1 Current profile during the gripping process

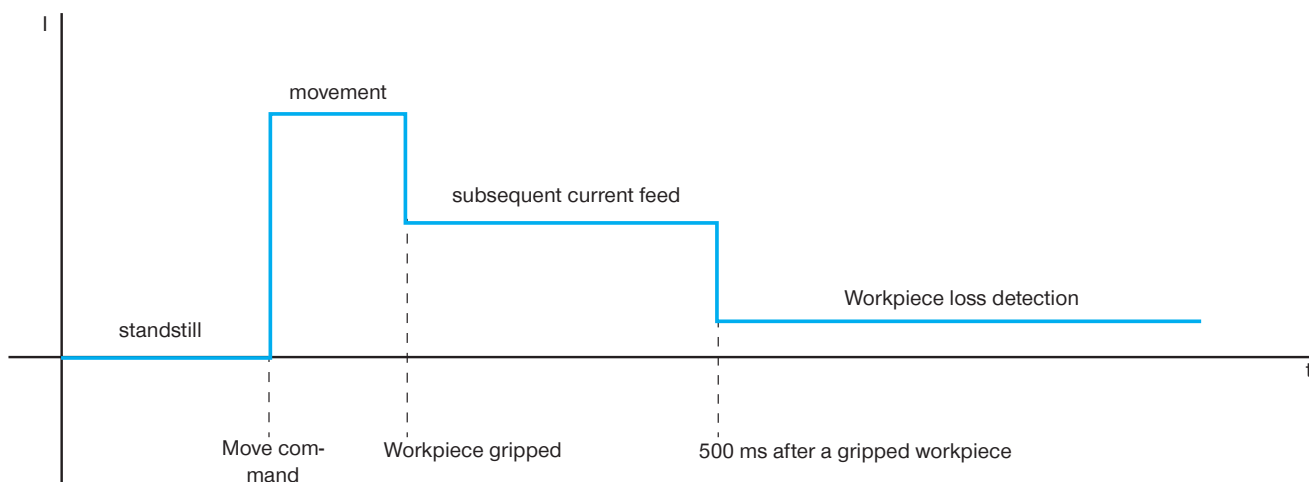

INFORMATION



- ▶ If a workpiece is lost, the product moves to the end position and displays an error message.
- ▶ For more information, please refer to the "Error diagnosis" section.

11.3 Minimum positioning path

The product requires a certain minimum positioning path to reach the desired gripping force.

INFORMATION



- ▶ You can find the information in the technical data sheet on our website.
- ▶ Please contact Customer Service if you have any questions.

12 Operation

12.1 Operating Freedrive

INFORMATION



Freedrive is only available for products HRC-03-118505 and HRC-03-118506.

The product is equipped with a Freedrive button to soft-switch the robot and move it manually.

- ▶ Press and hold the Freedrive button.
- ⇒ The robot can be moved manually.
- ▶ Move the robot to the desired position.
- ▶ Release the Freedrive Button again as soon as you have reached the desired position.
- ⇒ The robot and product stop at this position.

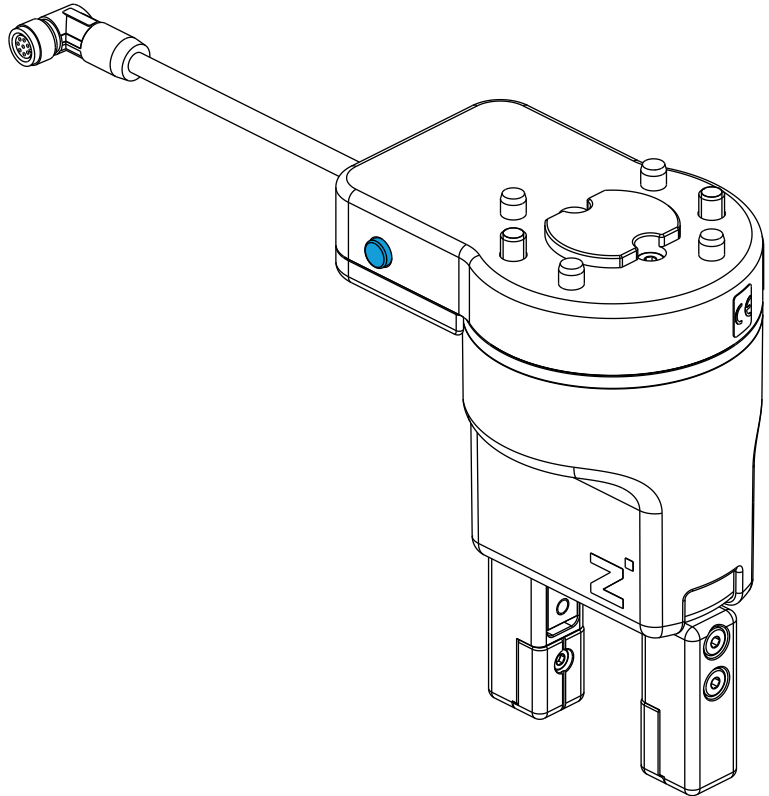

INFORMATION



- ▶ Details about activation can be found in the information from the robot manufacturer.

12.2 Setting the gripping force

- ▶ Secure the workpieces to prevent them from falling.

The gripping force can be adjusted in four stages using a rotary switch.

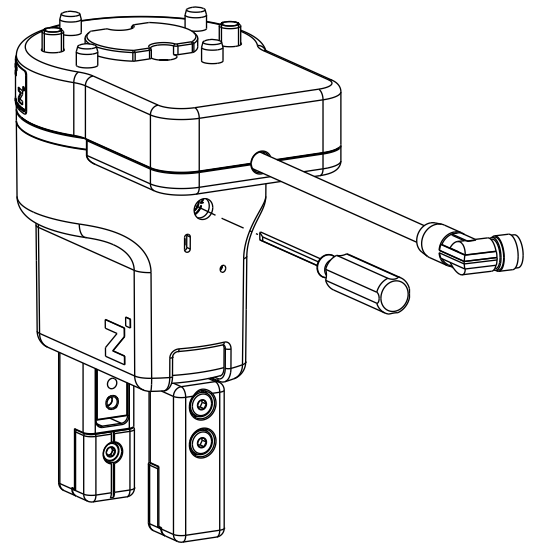

12.3 Emergency release

CAUTION



Risk of injury due to uncontrolled movements

Risk of injury in the event of uncontrolled movement of the product when the power supply is connected.

- ▶ Switch off the power supply to the machine before carrying out any work.
- ▶ Secure the power supply against being switched on unintentionally.
- ▶ Check the machine for any residual energy that may be present.

CAUTION



Risk of injury in case of non-compliance

- ▶ Disconnect the actuator voltage before pressing the emergency release.

INFORMATION



In the event of a power failure, the jaws remain in their positions and the gripping force of the product stays constant.

The product has an emergency release that can be unlocked mechanically and allows the jaws to be opened.

- ▶ Please contact Customer Service if you have any questions.

The product features an emergency release that can be mechanically opened with an Allen key in the event of a power failure.

- ▶ Secure the workpieces to prevent them from falling.
- ▶ Actuate the emergency release with a corresponding Allen key.
 - ▶ Use a wrench size of 1.5 mm.

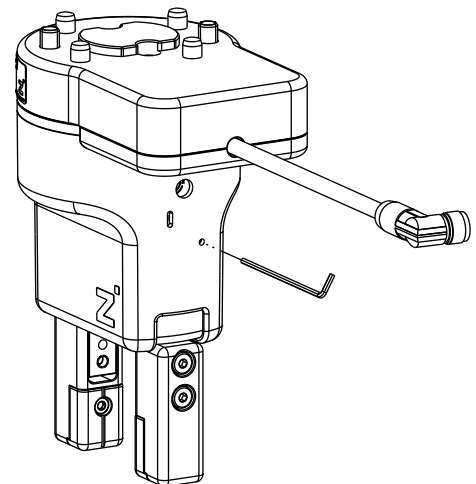

13 Gripping force charts

INFORMATION



- ▶ You can find the information in the technical data sheet on our website.
- ▶ Please contact Customer Service if you have any questions.

14 Error diagnosis

14.1 Status of the LED display

| Status | Meaning | Measure |
|--|---|--------------------------------------|
| ● LED lights up continuously green. | <ul style="list-style-type: none"> • No error | - |
| ○ LED does not light up. | | |
| ● LED lights up continuously green. | <ul style="list-style-type: none"> • Loss of workpiece detected. | - |
| ⊗ LED flashes red. | | |
| ○ LED does not light up. | <ul style="list-style-type: none"> • Actuator voltage not OK | - |
| ● LED lights up continuously red. | | |
| ○ LED does not light up. | Error | - |
| ⊗ LED flashes red. | | |
| ⊗ The green and red LEDs flash simultaneously. | <ul style="list-style-type: none"> • Product does not have any reference position. | ▶ A reference run must be performed. |
| ⊗ The green and red LEDs flash alternately. | <ul style="list-style-type: none"> • A reference run is performed. | - |

15 Maintenance

NOTICE



Material damage resulting from blowing out with compressed air

Blowing out the product with compressed air can cause malfunctions.

- ▶ Never purge the product with compressed air.

NOTICE



Material damage caused by unsuitable cleaning materials

Seals, insulation, coatings and other surfaces may be damaged by solvent-based cleaning agents.

- ▶ Make sure that no liquids penetrate the product.
- ▶ Use chemically and biologically neutral cleaning agents.
- ▶ Use cleaning agents that are categorized as being nonhazardous to health.
- ▶ Use soft, lint-free cloths for cleaning the surface.

The use of the following cleaning agents is strictly prohibited:

- Acetone
- Cleaning solvent
- Nitrocellulose thinner/turpentine oil (solvents)

NOTICE



Contamination of the environment due to escaping lubricants

Lubricants can escape through moving machine parts. This can lead to contamination of the machine, the workpiece and the environment.

- ▶ Remove leaking lubricant immediately and thoroughly.

Maintenance-free operation of the product is guaranteed for up to 10 million cycles.

- ▶ Note that the product could become damaged under the following circumstances:
 - Dirty environment
 - Improper use and use that does not comply with the performance data
 - Permissible temperature range not observed
 - ▶ Even though the product is maintenance-free as mentioned above, perform a regular visual inspection to check for any damage or contamination.
 - ▶ Have maintenance work that requires disassembly of the product performed by customer service only.
- ⇒ Dismantling and reassembling the product without authorization may result in complications, as special installation equipment is required in some cases. Zimmer Group GmbH accepts no liability for any resulting malfunctions or damage.

16 Decommissioning/disposal

INFORMATION



When the product reaches the end of its operational phase, it can be completely disassembled and disposed of.

- ▶ Disconnect the product completely from the power supply.
- ▶ Dispose of the components properly according to the material groups.
- ▶ Comply with the locally applicable environmental and disposal regulations.

17 RoHS declaration

in terms of the EU Regulation 2011/65/EU

Name and address of the manufacturer:

Zimmer Group GmbH

Am Glockenloch 2
77866 Rheinau, Germany

+49 7844 9138 0

info@zimmer-group.com

www.zimmer-group.com

We hereby declare that the incomplete machine described below

Product designation: 2-jaw parallel gripper

Type designation: HRC-03

conforms to the requirements of the directive in its design and the version we put on the market.

Michael Hoch

Authorized representative for the
compilation of relevant technical
documents

Rheinau, Germany, 2019-09-02

(Place and date of issuance)

Martin Zimmer
(Legally binding signature)
Managing Partner

18 Declaration of Incorporation

In terms of the EU Machinery Directive 2006/42/EC (Annex II 1 B)

Name and address of the manufacturer:

Zimmer Group GmbH

 Am Glockenloch 2
77866 Rheinau, Germany

 +49 7844 9138 0

 info@zimmer-group.com

 www.zimmer-group.com

We hereby declare that the incomplete machine described below

Product designation: 2-jaw parallel gripper

Type designation: HRC-03

conforms to the requirements of the Machinery Directive, 2006/42/EC, Article 2g, Annex VII, b – Annex II, b, in its design and the version we put on the market.

We hereby confirm that all the relevant basic health and safety requirements for the product have been observed and implemented.

A full list of applied standards can be obtained from the manufacturer.

We also declare that the specific technical documents were produced in accordance with Annex VII Part B of this Directive. We undertake to provide the market supervisory bodies with electronic versions of special documents for the incomplete machine through our documentation department, should they have reason to request them.

The incomplete machine may only be commissioned if it has been ascertained, if applicable, that the machine or system in which the incomplete machine is to be installed satisfies the requirements of Directive 2006/42/EC on Machinery and an EC Declaration of Conformity has been drawn up in accordance with Annex II 1 A.

Kurt Ross

Authorized representative for the
compilation of relevant technical
documents

Rheinau, Germany, 2019-09-02

(Place and date of issuance)



Martin Zimmer
(Legally binding signature)
Managing Partner

19 Declaration of Conformity

As defined by the EC Directive 2014/30/EU on electromagnetic compatibility

Name and address of the manufacturer:

Zimmer Group GmbH

📍 Am Glockenloch 2
77866 Rheinau, Germany

☎ +49 7844 9138 0

✉ info@zimmer-group.com

🌐 www.zimmer-group.com

We hereby declare that the product described below

Product designation: 2-jaw parallel gripper

Type designation: HRC-03

conforms to the requirements of the 2006/42/EC directive in its design and the version we put on the market.

The following harmonized standards have been used:

| | |
|------------------|--|
| DIN EN ISO 12100 | Safety of machinery - General principles for design - Risk assessment and risk reduction |
| DIN EN 61000-6-3 | EMC Generic standard, Emission standard for residential, commercial and light-industrial |
| DIN EN 61000-6-2 | EMC Generic standard, Emission standard for industrial environments |
| DIN EN 61000-6-4 | EMC Generic standard, Immunity for industrial environments |

A full list of applied standards can be obtained from the manufacturer.

Kurt Ross

Authorized representative for the compilation of relevant technical documents

Rheinau, Germany, 2019-09-02

(Place and date of issuance)



Martin Zimmer
(Legally binding signature)
Managing Partner