

CLAMPING ELEMENTS | PNEUMATIC

MCP1201A

▶ PRODUCT ADVANTAGES



- ▶ **small construction**
For all common miniature profile rail guides
- ▶ **Energize to close (NO)**
Closing with pressure
- ▶ **high durability**
Up to 5 million static clamping cycles

▶ TECHNICAL DETAILS



- ① **Miniature profile rail guide**
 - Available for all common miniature profile rail guides
- ② **Wedge-type gear**
 - Power transmission between piston and clamping jaw
- ③ **Clamping jaw**
 - Pressed at the free surfaces of the profile rail guide
- ④ **Housing**
- ⑤ **Pneumatic piston**
 - The piston moves the wedge-type gear longitudinally
- ⑥ **Sliding block**
 - For floating bearings

▶ INFORMATION ON THE PRODUCTS

APPLICATION SCENARIOS

- ▶ **Clamping of machine tables**
- ▶ **Positioning of axes**
- ▶ **Fixing of vertical axes in neutral position**

FURTHER INFORMATION

- ▶ **Special variants on request, e.g.**
With additional air connection (from above, from the front)

Track manufacturer	Rail type	Rail size	Carriage type
MISUMI	STZL (Miniature)	12(13)	SSZSB

TECHNICAL DRAWINGS

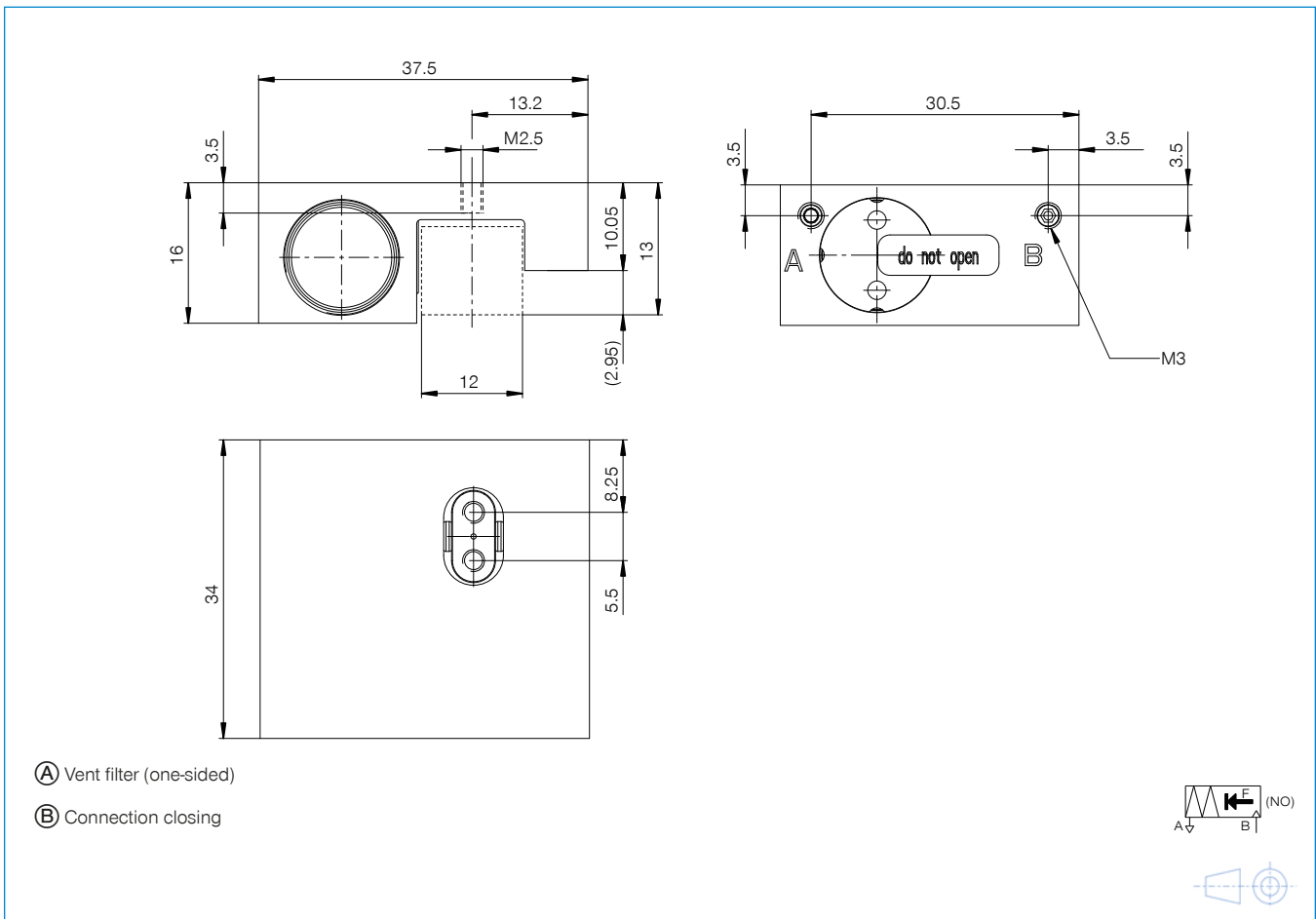

TECHNICAL DATA

Order No.	MCP1201A
Operation	pneumatic
Holding force	280 [N]
Theoretical holding force ($\mu=0,1$)	350 [N]
PLUS connection possible	No
Operating pressure	2 ... 6.5 [bar]
Nominal operating pressure	6 [bar]
B10d value	5,000,000
Positioning accuracy +/-	0,05 [mm]
Opening time	0.015 [s]
Closing time	0.01 [s]
Operating temperature	-10 ... +70 [°C]
Weight	0.091 [kg]
Function	Clamping
Condition	NO (Normally Open) open without pressure
Installation direction	from above
Masking tape can be used	with masking tape
Air volume per cycle	2 [cm ³]

Schematic drawing. General tolerances according to DIN ISO 2768 T1-4/T2-H. Edges according to ISO 13715. Element has no guiding properties. Guidance must be external. The holding force is the maximum force that can be applied in the axial direction. Each clamping and braking element is tested in a 100% inspection before delivery for the specified holding forces on a hardened steel rail with a lightly oiled lubricating layer (ISO-VG 68). The use of other lubricants or rail coatings can influence the coefficient of friction. The operating instructions must be observed before commissioning. We reserve the right to make technical changes in the course of further development. The latest and further data can be found online and in the operating instructions at www.zimmer-group.com.