

# CLAMPING ELEMENTS | ELECTRIC

## LKE1501AS1 + PLKE15-5-5

### ▶ PRODUCT ADVANTAGES

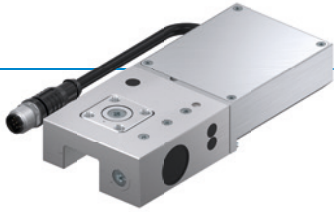

- ▶ **Energy-efficient (bistable)**  
Opens and closes using 24 V DC voltage
- ▶ **Integrated electronics**  
Digital control and status signals
- ▶ **Flexible cable outlet**  
For maximum space utilization

### ▶ TECHNICAL DETAILS

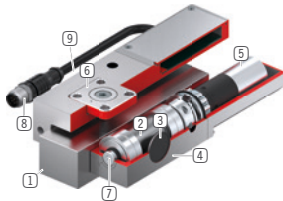

- ① **Profile rail guide**
  - Available for all common profile rail guides
- ② **Eccentric gear**
  - Power transmission between motor and clamping jaw
- ③ **Clamping jaw**
  - Pressed at the free surfaces of the profile rail guide
- ④ **Housing**
- ⑤ **electric drive**
  - For generating clamping force
- ⑥ **Sliding block**
  - For floating bearings
- ⑦ **Emergency actuation**
  - Manual opening possible in case of power supply failure
- ⑧ **Electrical connecting cable**
  - Control and power supply
- ⑨ **Adjusting screw**
  - Correction of the rail tolerance

### ▶ INFORMATION ON THE PRODUCTS

APPLICATION SCENARIOS

- ▶ **Axes with electric positioning**
- ▶ **Table traverses in medical applications**
- ▶ **Electric clamping of machine tables**

FURTHER INFORMATION

- ▶ **Spacer plate**  
In addition, a spacer plate might have to be ordered as height compensation, depending on the height of the rail carriage (dimension D).

Track manufacturer	Rail type	Rail size	Carriage type
THK	SHS	15	SHS..R

## ▶ TECHNICAL DRAWINGS

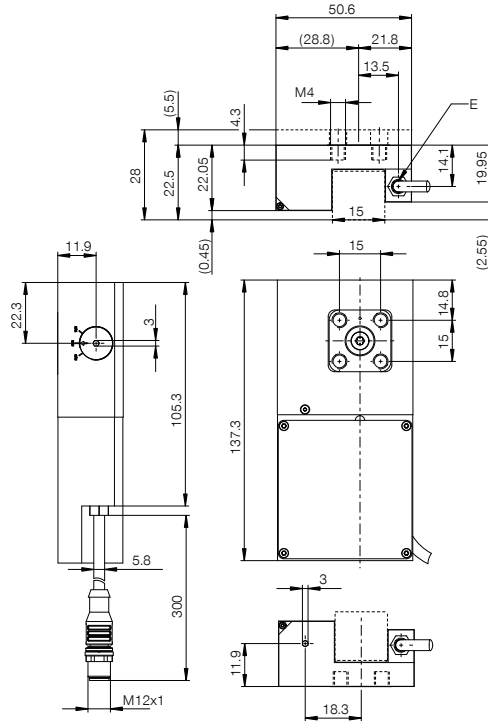

Ⓔ Electrical connection cable



## ▶ TECHNICAL DATA

Order No.	LKE1501AS1 + PLKE15-5-5
Operation	electric
Holding force	600 [N]
Theoretical holding force ( $\mu=0,1$ )	750 [N]
Voltage	24 [V]
Current consumption max.	1.0 [A]
Protection to IEC 60529	IP64
B10d value	500,000
Positioning accuracy +/-	0,05 [mm]
Opening time	0.5 [s]
Closing time	0.5 [s]
Operating temperature	5 ... +50 [°C]
Weight	0.62 [kg]
Function	Clamping
Condition	N (bistable) remains in current position
Installation direction	from above
Masking tape can be used	with masking tape
Cable length	0.3 [m]

Schematic drawing. General tolerances according to DIN ISO 2768 T1-4/T2-H. Edges according to ISO 13715. Element has no guiding properties. Guidance must be external. The holding force is the maximum force that can be applied in the axial direction. Each clamping and braking element is tested in a 100% inspection before delivery for the specified holding forces on a hardened steel rail with a lightly oiled lubricating layer (ISO-VG 68). The use of other lubricants or rail coatings can influence the coefficient of friction. The operating instructions must be observed before commissioning. We reserve the right to make technical changes in the course of further development. The latest and further data can be found online and in the operating instructions at [www.zimmer-group.com](http://www.zimmer-group.com).